

CARRILLO RESIDENCE

DRB 07082021 - Reduced Plans and Renderings (provided to the DRB on May 28, 2020 and City Council)

REVISION

MARK DATE REVISIONS



EC + Associates
 engineering

8207 BROOKGREEN ROAD
 DOWNEY, CA 90240
 P: 562 708 3586 P: 562 714 2886

OWNER:
 MR. EDUARDO J. CARRILLO

ADDRESS:
 8207 BROOKGREEN RD.
 DOWNEY, CA 90240

PROPOSED
 NEW 2-STORY HOUSE

PROJECT ADDRESS:
 1248 CORONA DR. GLENDALE, CA 91205
 VACANT LAND,
 GLENDALE CA 91205

TITLE
 TITLE SHEET

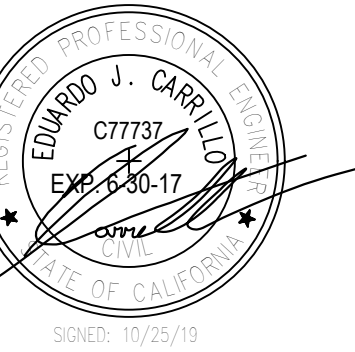

| | |
|----------------|----------|
| JOB #: | DRAWN: |
| 15-000 | 07773 |
| DATE: | CHECKED: |
| 12 / 22 / 2016 | E.C. |

A-0.0
 SHEET OF

ARCHITECTURAL ABBREVIATIONS

| | | | | | | | |
|-------|-----------------------|-------|------------------------|-------|--------------------------------------|--------|------------------------|
| @ | ANGLE | EA | EACH | MAX | MAXIMUM | SHT | SHEET |
| ∅ | CENTERLINE DIAMETER | EJ | EXPANSION JOINT | MB | MACHINE BOLT | SHTG | SHEATHING |
| AB | ANCHOR BOLT | ELEC | ELECTRICAL | MC | MEDICINE CABINET | SHWR | SHOWER |
| A/C | AIR CONDITIONING | ENCL | ENCLOSURE | MECH | MECHANICAL | SIM | SIMILAR |
| AC | ASPHALT CONCRETE | EQ | EQUAL | MED | MEDIUM | SKL | SKYLIGHT |
| ADJ | ADJACENT | EW | EACH WAY | MFG | MANUFACTURER | SL | SLIDER (WINDOW) |
| AFF | ABOVE FINISH FLOOR | (E) | EXISTING | MIN | MINIMUM | SLDG | SLIDING |
| ALUM | ALUMINUM | EXT | EXTERIOR | MISC | MISCELLANEOUS | SQ | SQUARE |
| | | FAU | FORCED AIR UNIT | MTL | METAL | STL | STEEL |
| | | FF | FINISH FLOOR | N | NORTH | STOR | STORAGE |
| | | FG | FIXED GLASS | NAT | NATURAL | STRUCT | STRUCTURAL |
| BD | BOARD | FRMS | FLATHEAD MACHINE SCREW | NIC | NOT IN CONTRACT | T | TREAD |
| BLDG | BUILDING | FIN | FINISH | NO | NUMBER | T&B | TOP & BOTTOM |
| BLK | BLOCK | FJ | FLOOR JOIST | NTS | NOT TO SCALE | T&G | TONGUE AND GROOVE |
| BLKG | BLOCKING | FO | FACE OF | OC | ON CENTER | TC | TRASH COMPACTOR |
| BM | BEAM | FLR | FLOOR | O/ | OVER | TO | TOP OF |
| BO | BOTTOM OF FRAMING | FLUOR | FLUORESCENT | OBS | OBSCURE | TOB | TOP OF BEAM |
| BOF | BOTTOM OF FRAMING | FND | FOUNDATION | OC | ON CENTER | TOM | TOP OF MASONRY |
| BO | BOTTOM OF | FTG | FOOTING | OD | OUTSIDE DIAMETER | TOP | TOP OF PARAFET |
| BOBM | BOTTOM OF BEAM | FRWS | FLATHEAD WOOD SCREW | OH | OVERHEAD | TOPL | TOP OF PLATE |
| | | FURR | FURRED | OPG | OPENING | TOS | TOP OF SHEETING |
| | | | | OS | OVERFLOW SCUPPER | THK | THICK |
| CAB | CABINET | GA | GAUGE | PERF | PERFORATE | TMPR | TEMPERED GLASS |
| CB | CATCH BASIN | GD | GARBAGE DISPOSAL | PL | PROPERTY LINE | TV | TELEVISION |
| CJ | CONTROL JOINT | GLB | GLU LAM BEAM | PLYWD | PLYWOOD | TYP | TYPICAL |
| CLG | CEILING | GS | GALVANIZED STEEL | PR | PAIR | UNO | UNLESS NOTED OTHERWISE |
| CLR | CLEAR | GYP | GYPSPUM | PVC | POLYVINYL CHLORIDE | | |
| CMU | CONCRETE MASONRY UNIT | GB | GYPSPUM BOARD | R | RADIUS/RISER | VIF | VERIFY IN FIELD |
| CO | CLEANOUT | HB | HOSE BIBB | RD | ROOF DRAIN | | |
| COL | COLUMN | HDR | HEADER | RDWD | REDWOOD | W/ | WITH |
| COMP | COMPOSITE SHINGLES | HGT | HEIGHT | HTR | HEATER | W/O | WITHOUT |
| CONC | CONCRETE | HTR | HEATER | HVAC | HEATING/VENTILATING/AIR CONDITIONING | WC | WATER CLOSET |
| CONST | CONSTRUCTION | HW | HOT WATER | REFR | REFRIGERATOR | WD | WOOD |
| CONT | CONTINUOUS | IN | INCH | REIN | REINFORCEMENT | WH | WATER HEATER |
| CSK | COUNTER SINK | INT | INTERIOR | REQD | REQUIRED | WI | WROUGHT IRON |
| CSMT | CASEMENT | INSUL | INSULATION | RM | ROOM | WP | WATERPROOF |
| CT | CERAMIC TILE | JST | JOIST | RO | ROUGH OPENING | WR | WATER RESISTANT |
| CTS | COUNTERSINK CENTER | LAM | LAMINATE | RS | ROUGH SAWN | WWF | WELDED WIRE FABRIC |
| CTR | CENTER | LAV | LAVATORY | RWD | REDWOOD | WWM | WELDED WIRE MESH |
| CW | COLD WATER | LAV | LAVATORY | SF | SQUARE FEET | | |
| | | INSUL | INSULATION | SHLF | SHELF | | |
| DS | DOWNSPOUT | LAV | LAVATORY | SHLV | SHELVING | | |
| DBL | DOUBLE | MATL | MATERIAL | SS | STAINLESS STEEL | | |
| DIA | DIAMETER | | | S&P | SHELF AND POLE | | |
| DIAG | DIAGONAL | | | S&P | SHELF AND POLE | | |
| DIM | DIMENSION | | | SEL | SELECT | | |
| DN | DOWN | | | SH | SINGLE HUNG | | |
| DR | DOOR | | | | | | |
| DW | DISHWASHER | | | | | | |

ARCHITECTURAL SYMBOLS

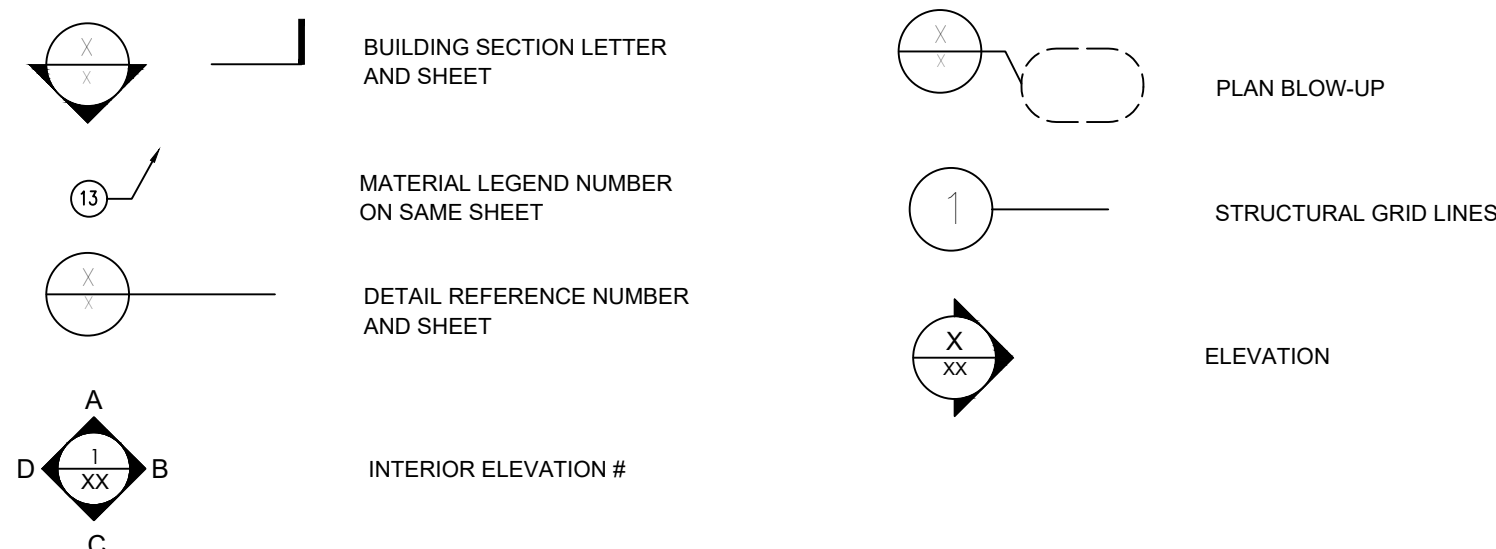

GENERAL NOTES

- ALL WORK SHALL CONFORM TO: (A) THE MINIMUM STANDARDS OF THE LATEST EDITION OF THE INTERNATIONAL BUILDING CODE AND ALL RELATED DOCUMENTS PUBLISHED BY THE I.C.C. WHICH HAVE BEEN ADOPTED BY THE LOCAL GOVERNING AGENCY; (B) ALL REGULATIONS AND ORDINANCES OF ALL LOCAL GOVERNING AGENCIES; (C) ANY SPECIAL CONDITIONS REQUIRED BY THE LOCAL GOVERNING AGENCIES; AND (D) ALL CALIFORNIA STATE CODE AMENDMENTS (BUILDING STANDARDS CODE) TITLE 24.
- THE APPLICABLE CODES WILL INCLUDE, BUT SHALL NOT BE LIMITED TO:
 - 2016 CALIFORNIA RESIDENTIAL CODE (CRC)
 - 2016 CALIFORNIA BUILDING CODE (CBC)
 - 2016 CALIFORNIA ELECTRICAL CODE (CEC)
 - 2016 CALIFORNIA MECHANICAL CODE (CMC)
 - 2016 CALIFORNIA PLUMBING CODE (CPC)
 - 2016 CALIFORNIA ENERGY CODE (CENC)
 - CITY OF GLENDALE CODE
- ALL WORK DESCRIBED IN THE DRAWINGS SHALL BE VERIFIED BY THE CONTRACTOR FOR DIMENSION, GRADE, EXTENT AND COMPATIBILITY TO THE EXISTING SITE. ANY DISCREPANCIES AND UNEXPECTED CONDITIONS THAT AFFECT OR CHANGE THE WORK DESCRIBED IN THE CONTRACT DOCUMENTS SHALL BE BROUGHT TO THE ARCHITECT'S ATTENTION IMMEDIATELY. DO NOT PROCEED WITH THE WORK IN THE AREA OF DISCREPANCIES UNTIL ALL SUCH DISCREPANCIES ARE RESOLVED. IF THE CONTRACTOR CHOOSES TO DO SO, HE SHALL BE PROCEEDING AT HIS OWN RISK.
- OMISSIONS FROM THE DRAWINGS AND SPECIFICATION OR THE MISDESCRIPTION OF THE WORK WHICH IS MANIFESTLY NECESSARY TO CARRY OUT THE INTENT OF THE DRAWINGS AND SPECIFICATIONS, OR WHICH IS CUSTOMARILY PERFORMED, SHALL NOT RELIEVE THE CONTRACTOR FROM PERFORMING SUCH OMITTED OR MISDESCRIBED DETAILS OF THE WORK AS IF FULLY AND COMPLETELY SET FORTH AND DESCRIBED IN THE DRAWINGS AND SPECIFICATIONS.
- DIMENSIONS SHOWN SHALL TAKE PRECEDENCE OVER DRAWINGS SCALE OR PROPORTION. LARGER SCALE DRAWINGS SHALL TAKE PRECEDENCE OVER SMALLER SCALE DRAWINGS.
- APPROVED NUMBERS OR ADDRESSES (PER CITY OF LOS ANGELES) SHALL BE PROVIDED IN SUCH A POSITION AS TO BE PLAINLY VISIBLE AND LEGIBLE FROM THE STREET OR ROAD FRONTING THE PROPERTY. CONTRACTOR SHALL COORDINATE THE LOCATION WITH THE ARCHITECT.
- THE CONTRACTOR SHALL COORDINATE WITH THE OWNER FOR THE SELECTION OF ALL PLUMBING FIXTURES INCLUDING TOILETS, TUB/SHOWER, LAVATORIES, SINKS AND ALL APPROPRIATE FAUCETS, TRIM AND DRAINS. THE OWNER SHALL SELECT ALL COLORS, FINISH AND OPTIONS.
- THE CONTRACTOR SHALL BE RESPONSIBLE FOR THE DESIGN AND INSTALLATION OF THE MECHANICAL HEATING AND DISTRIBUTION SYSTEM IN COMPLIANCE WITH APPLICABLE CODES AND REGULATIONS.
- THE CONTRACTOR SHALL COORDINATE WITH OWNER FOR THE SELECTION OF ALL ELECTRICAL LIGHT FIXTURES (THEIR COLOR, TYPE AND FINISH), AND SWITCHPLATED AND OUTLETS (COLOR AND TYPE). THE CONTRACTOR SHALL VERIFY ALL LOCATIONS AND HEIGHTS OF ALL OUTLETS, LIGHTING FIXTURES, ETC. WITH THE ARCHITECT.
- THE CONTRACTOR SHALL COORDINATE WITH OWNER FOR THE SELECTION OF ALL KITCHEN APPLIANCES (COLOR, TYPE AND OPTIONS).
- THE CONTRACTOR SHALL COORDINATE WITH THE OWNER FOR THE SELECTION AND PROPER LOCATIONS OF ALL BATHROOM SPECIALTIES INCLUDING, BUT NOT LIMITED TO, MEDICINE CABINETS, MIRRORS, TOWEL BARS AND HOOKS, TOILET PAPER DISPENSER, SOAP DISH AND SHOWER ENCLOSURE.
- THE CONTRACTOR SHALL COORDINATE WITH THE OWNER FOR THE DESIGN OF BUILT-IN CABINETS INCLUDING DOOR AND DRAWER LOCATIONS, TYPES OF HINGES, PULLS AND SLIDING HARDWARE. THE OWNER SHALL SELECT THE TYPE OF MATERIALS, COLOR AND FINISH FOR CABINETS.
- THE CONTRACTOR SHALL COORDINATE WITH THE OWNER FOR THE SELECTION OF ALL INTERIOR FINISHES INCLUDING FLOOR COVERINGS AND UNDERLAYMENTS, PAINT (INCLUDING NUMBER OF COATS), OTHER WALLCOVERINGS, BASE AND CASE, LAMINATES, TILE, ETC.

PROJECT DATA

| | |
|--------------------------|---|
| OWNER: | EDUARDO J. CARRILLO |
| PROJECT ADDRESS: | 1248 CORONA DRIVE |
| NUMBER OF STORY: | TWO |
| LOT SIZE (AREA): | 8,889 sq.ft. |
| LEGAL DESCRIPTION: | A.P.N. 5679-016-001 5679-016-002 5679-016-024 |
| | TRACT: 6759 |
| | LOTS: 148 147 170 |
| ZONE: | R1R (RESTRICTED RESIDENTIAL FAR III) |
| OCCUPANCY GROUP: | R-3 & U-1 |
| TYPE OF CONSTRUCTION: | V-B |
| MAX. HEIGHT ALLOWED: | 32 FEET |
| PROPOSED BLDG. HEIGHT: | 32 FEET |
| EXISTING NATURAL SLOPE | |
| GREATER THAN 40%..... | YES |
| AVERAGE NATURAL SLOPE: | 60% |
| TOTAL ALLOWED F.A.R. | 30% = (2,666 sq.ft.) |
| TOTAL PROPOSED F.A.R. | 28% = (2,247 sq.ft.) |
| PROPOSED PAVING AREA: | 12% = (1,063 sq.ft.) |
| PROPOSED LANDSCAPE AREA: | 60% = (5,574 sq.ft.) |
| PROPOSED SETBACKS: | FRONT=15'-0" SIDE= 12'-6" REAR= 10'-0" |

FLOOR AREA ANALYSIS

| | |
|---|--------------|
| GARAGE: | 545 sq.ft. |
| STAIRCASE AREA: | 150 sq.ft. |
| LAUNDRY ROOM: | 32 sq.ft. |
| FIRST FLOOR: | 1,537 sq.ft. |
| SECOND FLOOR: | 580 sq.ft. |
| TOTAL GROSS AREA: | 2,844 sq.ft. |
| NOTE: UP TO 500 sq.ft. OF GARAGE NOT PART OF GARAGE | |
| REVISE F.A.R.: | 2,344 sq.ft. |

SCOPE OF WORK:

CONSTRUCTION OF A NEW TWO STORY SINGLE FAMILY DWELLING ON VACANT LOTS

VICINITY MAP



SHEET INDEX

| | |
|--------|--|
| A-0.0 | TITLE SHEET |
| T-1.0 | TOPOGRAPHIC SURVEY MAP |
| L1.01 | IRRIGATION PLAN |
| L1.02 | IRRIGATION DETAILS |
| L2.01 | LANDSCAPE PLAN (PLANTING PLAN) |
| L2.02 | PLANTING DETAILS |
| A-1.1 | SITE PLAN |
| A-1.2 | SITE PLAN (CUT ARE TABULATION) |
| A-1.3 | ENLARGED SITE PLAN (RETAINING WALL & ELEVATIONS) |
| A-2.0 | GARAGE LEVEL |
| A-2.0a | FIRST FLOOR AREAS |
| A-2.0b | SECOND FLOOR AREAS |
| A-2.1 | FIRST FLOOR |
| A-2.2 | SECOND FLOOR |
| A-2.3 | ROOF PLAN |
| A-2.4 | DOOR AND WINDOW SCHEDULE |
| A-3.1 | WEST EXTERIOR ELEVATION |
| A-3.2 | NORTH & SOUTH EXTERIOR ELEVATIONS |
| A-3.3 | COLORLED WEST EXTERIOR ELEVATION |
| A-3.4 | NORTH & SOUTH EXTERIOR ELEVATIONS |
| A-4.0 | SITE CROSS SECTIONS "A" & "B" |
| A-4.1 | SITE CROSS SECTIONS "C" & "D" |
| A-4.2 | SITE CROSS SECTIONS "E" |

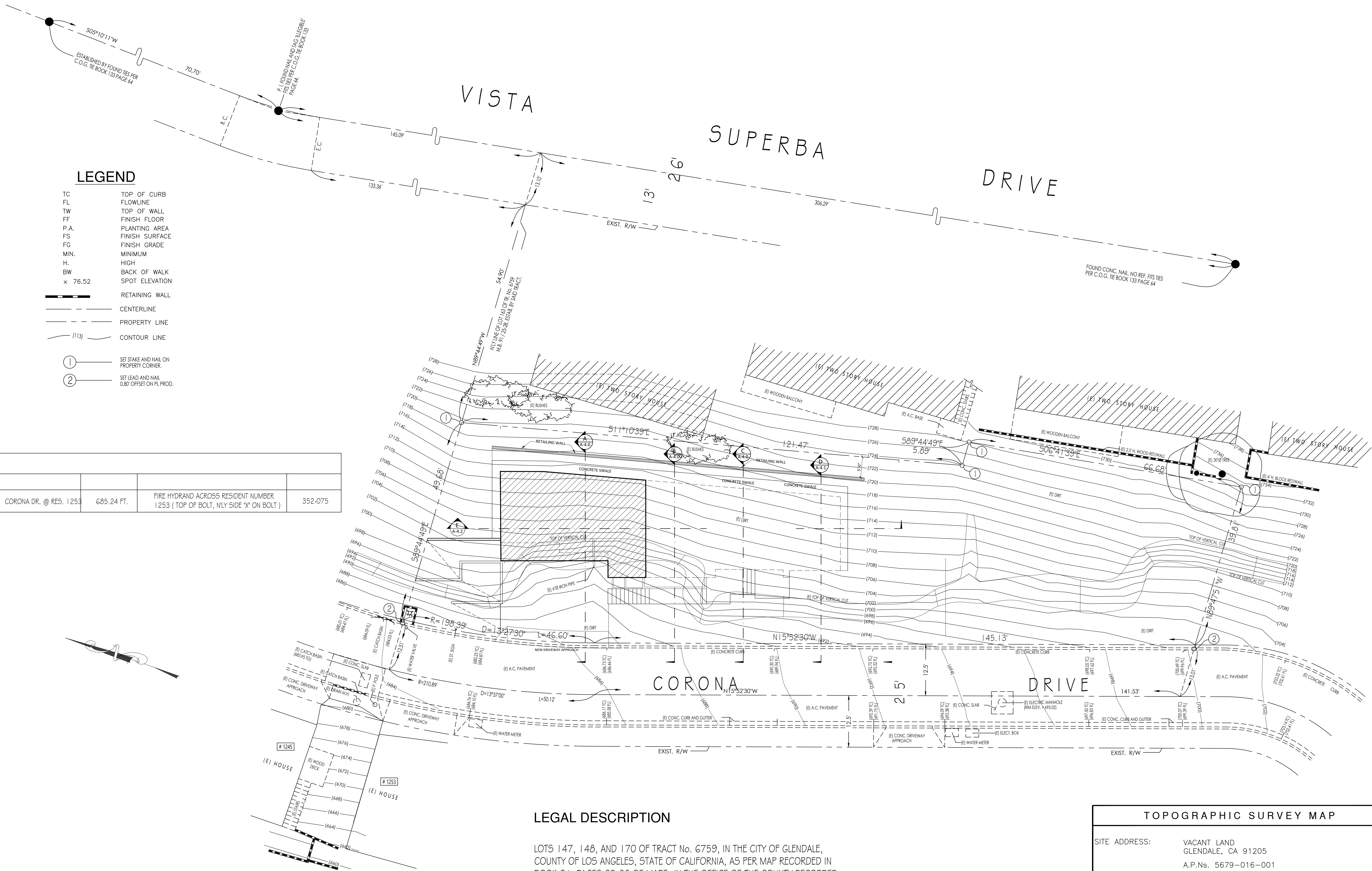

LEGEND

- TC TOP OF CURB
- FL FLOWLINE
- TW TOP OF WALL
- FF FINISH FLOOR
- P.A. PLANTING AREA
- FS FINISH SURFACE
- FG FINISH GRADE
- MIN. MINIMUM
- H. HIGH
- BW BACK OF WALK
- x 76.52 SPOT ELEVATION
- RETAINING WALL
- CENTERLINE
- PROPERTY LINE
- (113) CONTOUR LINE
- ① SET STAKE AND NAIL ON PROPERTY CORNER.
- ② SET LEAD AND NAIL 0.80' OFFSET ON PL PROD.

| | | | |
|------------------------|------------|--|---------|
| CORONA DR. @ RES. 1253 | 685.24 FT. | FIRE HYDRANT ACROSS RESIDENT NUMBER 1253 (TOP OF BOLT, NLY SIDE "X" ON BOLT) | 352-075 |
|------------------------|------------|--|---------|

LEGAL DESCRIPTION

LOTS 147, 148, AND 170 OF TRACT No. 6759, IN THE CITY OF GLENDALE, COUNTY OF LOS ANGELES, STATE OF CALIFORNIA, AS PER MAP RECORDED IN BOOK 91, PAGES 25-28 OF MAPS, IN THE OFFICE OF THE COUNTY RECORDER OF SAID COUNTY.

TOPOGRAPHIC SURVEY MAP

SITE ADDRESS: VACANT LAND
GLENDALE, CA 91205
A.P.Ns. 5679-016-001
5679-016-002
5679-016-024

SCALE: 1"=10'

CITY OF GLENDALE

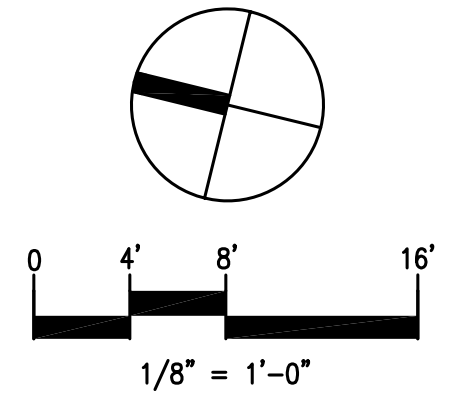
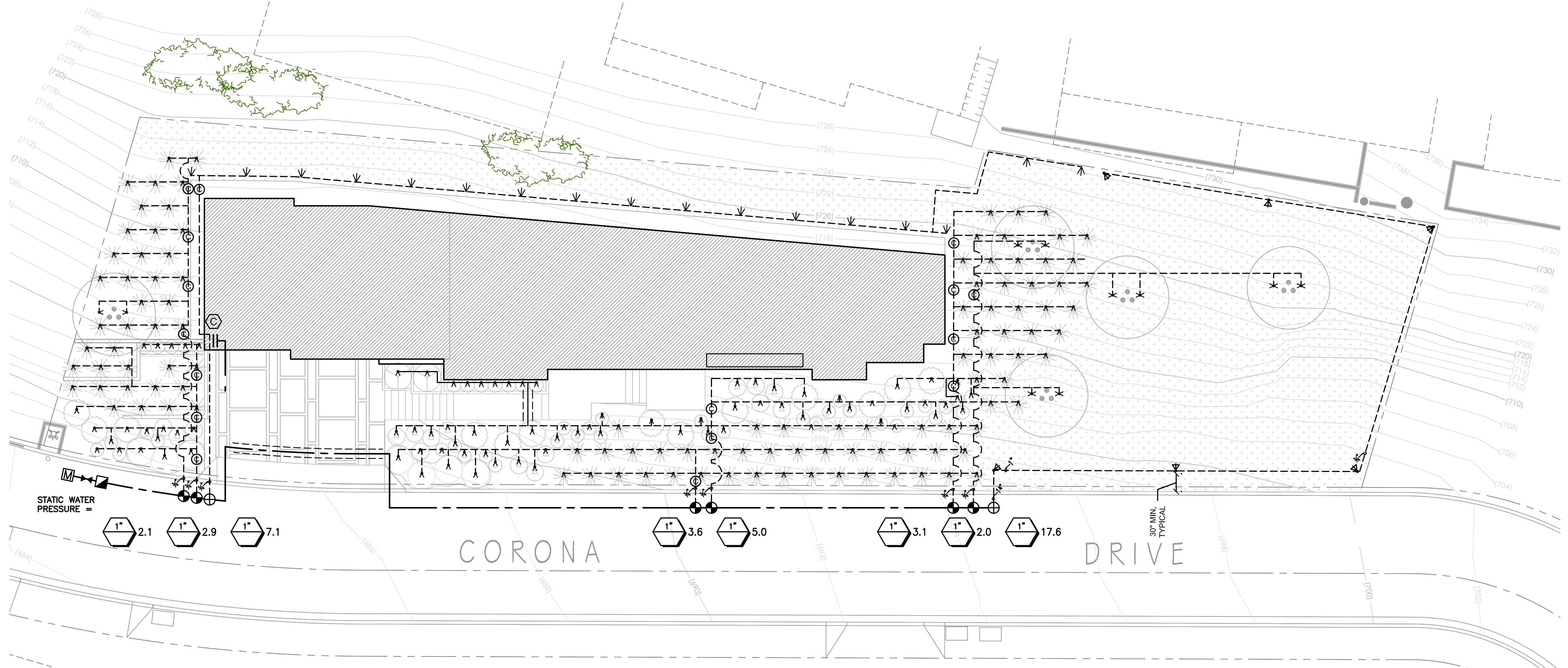

IRRIGATION NOTES

- DESIGN PRESSURE:** Irrigation design is based on a maximum demand of 17.6 GPM, and a minimum operating pressure of 40 PSI. The Contractor shall measure static pressure at the point of connection prior to installation. If the static pressure exceeds 400 PSI, install an inline pressure regulator as shown on the Backflow Preventor Detail, Sheet L1.02. Notify the Landscape Architect and Owner's Representative if the pressure is below the minimum operating pressure. Pressure regulating devices are required if water pressure is below or exceeds the recommended pressure of the specified devices.
- VERIFY FIELD CONDITIONS:** Do not willfully install the irrigation system as shown on the Drawings when it is obvious in the field that obstructions, grade differences, or discrepancies in area dimensions exist that might not have been considered in engineering. Such obstructions or differences shall be brought to the attention of the Owner's Representative. In the event this notification is not performed, the irrigation contractor shall assume the full responsibility for any revision necessary.
- PLAN VIEW DRAWING IS DIAGRAMMATIC:** Due to the scale of drawings, it is not possible to indicate or show all offsets, fittings, sleeves, which may be required. The Contractor shall accordingly, furnishing such fittings, sleeves, etc., as may be required to meet site conditions. Drawings are generally diagrammatic and indicative of the work to be installed. The Contractor shall install the work in such a manner as to avoid conflicts between irrigation systems, planting, other utilities and architectural features. Locations of trees to be planted takes precedence over irrigation pipes and equipment.
- MANUFACTURER'S DIRECTIONS:** Manufacturer's directions and detailed drawings shall be followed in all cases where the manufacturers of articles used in this Contract furnish directions covering points not shown in the Drawings.
- MATERIALS:** The Contractor shall furnish the articles, equipment, materials, or processes specified by name in the Drawings. A materials list shall be submitted prior to performing any work. Material list shall include manufacturer's name, model number, and description of all materials and equipment to be used. Substitutions of any equipment or materials for the equipment or materials listed on the Drawings may only be done with the written approval of the Owner's Authorized Representative. Equipment or materials installed or furnished without prior approval may be rejected and the Contractor may be required to remove such materials from the site at his own expense.
- BACKFLOW PREVENTION DEVICE:** All irrigation equipment installed shall be downstream of an approved, working Reduced Pressure type backflow prevention device as shown on plan.
- ANTI-DRAINAGE DEVICES:** Check valves or anti-drain valves are required on all sprinkler heads where low point drainage could occur. Install inline check valves as indicated on the plans and in any other locations as needed to prevent low point drainage.
- PIPE AND FITTINGS:** PVC pipe class/schedule and sizes shall conform to those shown in irrigation equipment legend and sizing callouts. Substitution of smaller pipe sizes or different class/schedule is not permitted. PVC solvent weld fittings shall be Schedule 40. Solvent cement and primer shall be of type and installation methods prescribed by pipe manufacturer.
- NIPPLES AND RISERS:** Nipples and Risers shall be Schedule 80 PVC. Threaded ends shall be machined threads only. Machined threads not permitted.
- MAIN LINE LEAK TEST:** Test the entire main line piping system prior to the installation of valves for no less than 2 hours under hydrostatic pressure of 150 pounds per square inch and prove tight; apply pressure by a force pump provided by Contractor. If leaks develop, replace the joints, or pipe, and repeat test. Perform all tests prior to backfilling trenches. Perform test in presence of the Owner's Authorized Representative
- FIELD ADJUSTMENTS:** The Contractor may need to adjust the angles, directions and/or flowrate of the emitters/nozzles to obtain the intended coverage of the landscape area. The Contractor will provide any additional heads, special nozzles, or patterns to achieve proper coverage without additional cost to the Owner.
- FLUSH SYSTEM:** After all new irrigation system valves, pipelines and assemblies are in place and connected, and prior to installation of distribution tubing and emitters, the control valves shall be opened and a full head of water used to flush out the system.
- FINAL OBSERVATION:** The Contractor shall operate each system in its entirety for Owner's Authorized Representative at time of final observation. Any items deemed not acceptable by the Owner's Authorized Representative shall be reworked to the complete satisfaction of the Owner's Authorized Representative.
- TURNOVER:** Upon completion, furnish the following: Any required and necessary descriptive literature for installed equipment, manuals, operating instructions, and manufacturer's warranties. One (1) set of special tools required for removing, disassembling, and adjusting each type of device installed. Guarantee Form.
- IRRIGATION CHART:** A diagram of the irrigation plan showing all zones shall be provided and kept with the irrigation controller.

IRRIGATION EQUIPMENT LEGEND

| SYMBOL | MANUFACTURER AND MODEL | REFERENCES | |
|-----------|---|------------|-------|
| | | DTL | SHEET |
| ⊕ | "RAIN BIRD" CONTROL VALVE "PEB", SIZE PER PLAN | C | L1.02 |
| ⊙ | "RAIN BIRD" DRIP CONTROL ZONE | D | L1.02 |
| ⊚ | "NIBCO" T-113 BRONZE GATE VALVE W/ WHEEL HANDLE, SIZE PER MAINLINE SIZE | E | L1.02 |
| ⊠ | "WILKENS" 975XL, 1", LOCATION TO BE DETERMINED, INSTALL IN PLANTING AREA | F | L1.02 |
| ⊕ | "RAIN BIRD" ESP4SMT w/ESPSM6 10-STATION CONTROLLER, WEATHER-BASED | G | L1.02 |
| ⊕ | "NDS" CHECK VALVE KSC-075-S, 3/4", INSTALL ON LATERAL LINE TO PREVENT DRAINAGE | - | - |
| M | DEDICATED IRRIGATION METER, INSTALLED BY GWP; 1" - CONFIRM LOCATION ON SITE | - | - |
| — | PRESSURIZED MAINLINE, 1 1/2", SCHEDULE 40 PVC; BURY PER TRENCHING DETAIL | H | L1.02 |
| — | LATERAL LINE, SCHEDULE 40 PVC, BURY 12" MINIMUM BELOW FINISH GRADE | H | L1.02 |
| --- | LATERAL LINE, UVR PVC, SCHEDULE 40, 3/4", ON GRADE, WITH SCHED 40 PVC FITTING; STAKE PIPE TO GRADE AT 8' ON CENTER USING #4 REBAR J-HOOKS | - | - |
| --- | SLEEVE (FOR MAINLINE, LATERALS, CONTROL WIRES), CLASS 315 PVC 2" THROUGH 4"; 2X DIAMETER OF SLEEVED PIPE(S) | H | L1.02 |
| NOT SHOWN | VALVE BOXES, NDS OR EQUAL, WITH HINGED COVER, LARGE-SIZE WITH TWO DRIP CONTROL ZONE PER BOX AS SHOWN. | - | - |
| NOT SHOWN | CONTROL AND COMMON WIRE #14 AWG-UF (DIRECT BURIAL) SOLID COPPER WIRE (BURY WITH MAIN LINE) UL APPROVED; CONTROL VALVE WIRE SHALL HAVE A MINIMUM OF EIGHT (8) DIFFERENT COLOR CODES; ALL CONTROL WIRES FROM CONTROLLER TO VALVES TO BE CONTINUOUS (NO FIELD SPLICES ALLOWED). SCOTCHLOK SEAL PACK CONNECTORS OR DRIP-SPLICE WIRE CONNECTOR AND SEALANT OR APPROVED EQUAL SHALL BE USED WHEN CONNECTION CONTROL WIRE TO CONTROL VALVES; INSTALL WIRES FOR ALL OPEN STATIONS ON CONTROLLER PLUS 4 EXTRA WIRES AT ENTIRE LENGTH | - | - |

IRRIGATION EMITTER LEGEND

| SYMBOL | MANUFACTURER AND MODEL | PSI | GPM | | | REFERENCES | |
|--------|--|-----|-----|-----|-----|------------|-------|
| | | | Q | H | F | DTL | SHEET |
| ∇ | "RAIN BIRD" BUBBLER PCT-05 ON 4" RISER (SCHED 80 PVC) | 30 | - | - | .08 | A | L1.02 |
| × | "RAIN BIRD" BUBBLER FULL CIRCLE 1401 4" RISER (SCH. 80 PVC) | 30 | - | - | .25 | A | L1.02 |
| ∇ | "RAIN BIRD" MPR NOZZLE -8H ON 12" RISER (SCHED 80 PVC) | 30 | - | .52 | - | A | L1.02 |
| ∇ | "RAIN BIRD" IMPACT ROTOR 2045-PJ-7LA ON 12" RISER (SCHED 80 PVC) | 40 | - | 2.1 | 2.1 | B | L1.02 |



| REVISIONS | DATE |
|-----------|------|
| 1. | |
| 2. | |
| 3. | |
| 4. | |
| 5. | |
| 6. | |
| 7. | |
| 8. | |



DRAWING STATUS:
CONSTRUCTION DOCUMENTS

DRAWN BY: JWM
CHECKED BY:
PROJECT NO. 15-0313
DATE: 2016.06.01

SHEET CONTENTS:

IRRIGATION PLAN

SHEET NUMBER:

L1.01

**WATER EFFICIENT LANDSCAPE ORDINANCE
PROJECT INFORMATION**

| | |
|-----------------------|--|
| DATE: | MAY 31, 2016 |
| TOTAL LANDSCAPE AREA: | 5,758.6 SQ. FT. |
| PROJECT TYPE: | SINGLE-FAMILY RESIDENTIAL |
| WATER SUPPLY TYPE: | POTABLE WATER, GLENDALE WATER AND POWER |
| APPLICANT: | JEFF MAXWELL, PLA CA#5774 JMD LANDSCAPE ARCHITECTURE 330 ARDEN AVENUE, SUITE 130 GLENDALE, CA 91203 323-491-3808 |
| PROPERTY OWNER: | EDUARDO J. CARRILLO 8207 BROOKGREEN RD. DOWNEY, CA 562-708-3586 |

I AGREE TO COMPLY WITH THE REQUIREMENTS OF THE WATER EFFICIENT LANDSCAPE ORDINANCE AND SUBMIT A COMPLETE LANDSCAPE DOCUMENTATION PACKAGE"
Jeff Maxwell 05/21/2016

LANDSCAPE DOCUMENTATION PACKAGE INCLUDES:

| | |
|--|-------------------------------------|
| 1. PROJECT INFORMATION | SHEET L1.02 |
| 2. WATER EFFICIENT LANDSCAPE WORKSHEET | SHEET L1.02 |
| 3. SOIL MANAGEMENT REPORT | (PROVIDED WITH CERT. OF COMPLETION) |
| 4. LANDSCAPE DESIGN PLAN | SHEET L2.01 |
| 5. IRRIGATION DESIGN PLAN | SHEET L1.01 |
| 6. GRADING DESIGN PLAN | SEE CIVIL ENGINEERING |

Upon project completion, a Certificate of Completion shall be filled out and certified by either the designer of the landscape plans, irrigation plans, or the licensed landscape contractor.

An irrigation audit report shall be completed at the time of final inspection.

WATER EFFICIENT LANDSCAPE WORKSHEET

MAXIMUM APPLIED WATER ALLOWANCE (MAWA)

- MAWA = (ET_o) (0.62) [(0.45xLA)+(0.55xSLA)]
- MAWA=MAXIMUM APPLIED WATER ALLOWANCE (GALLONS PER YEAR)
 - ET_o =REFERENCE EVAPOTRANSPIRATION (INCHES PER YEAR)
 - 0.55 =ET ADJUSTMENT FACTOR (ETAF)
 - LA =LANDSCAPE AREA INCLUDES SPECIAL LANDSCAPE AREA (SQ.FT.)
 - 0.62 =CONVERSION FACTOR (TO GALLONS PER SQ. FT.)
 - SLA =PORTION OF LANDSCAPE IDENTIFIED AS SPECIAL LANDSCAPE AREA (SQ.FT.)
 - 0.45 =ADDITIONAL ET ADJUSTMENT FACTOR FOR SLA (1.0-0.55=0.45)

ET_o =43.7
LA =5,758.6 S.F.
SLA =0
MAWA = (43.7) (0.62) [(0.55x5,758.6) + (0.45x0)] = 85,812.9

MAXIMUM APPLIED WATER ALLOWANCE = 85,813 GALLONS PER YEAR

ESTIMATED TOTAL WATER USE (ETWU)

- ETWU = (ET_o) (0.62) (ETAF x AREA)
- ETWU =ESTIMATED TOTAL WATER USE YEAR (GALLONS PER YEAR)
 - ET_o =REFERENCE EVAPOTRANSPIRATION (INCHES PER YEAR)
 - PF =PLANT FACTOR FROM WUCOLS
 - 0.62 =CONVERSION FACTOR
 - IE =IRRIGATION EFFICIENCY

| VALVE ZONE/ DESCRIPTION | WATER USE | PLANT FACTOR (PF) | IRR TYPE | IRR EFF (IE) | ETAF (PF/IE) | LANDSCAPE AREA (S.F.) | ETAF X AREA | EST. TOTAL WATER USE (ETWU) |
|---|-----------|-------------------|----------|--------------|--------------|-----------------------|----------------|-----------------------------|
| 1,2,4,5,6 ORNAMENTAL CONTAINER PLANTS | L | 0.2 | DRIP | 0.81 | 0.37 | 2,463.6 | 912.4 | 24,721.8 |
| 7 TREE BUBBLERS | L | 0.2 | DRIP | 0.81 | 0.37 | 56.4 | 20.9 | 566.0 |
| 3,8 HYDROSEED SLOPE (TEMP IRRIGATION) | L | 0.2 | SPRAY | 0.75 | 0.27 | 3,238.6 | 863.6 | 23,399.1 |
| TOTALS | | | | | | 5,758.6 | 1,797.0 | 48,687 |
| MAXIMUM ALLOWED WATER ALLOWANCE (MAWA) | | | | | | | | 85,813 |

ETAF CALCULATIONS

| | |
|---------------------|---------|
| TOTAL ETAF x AREA | 1,797.0 |
| TOTAL AREA | 5,758.6 |
| AVERAGE ETAF | 0.31 |
| AVERAGE ETAF < 0.55 | |

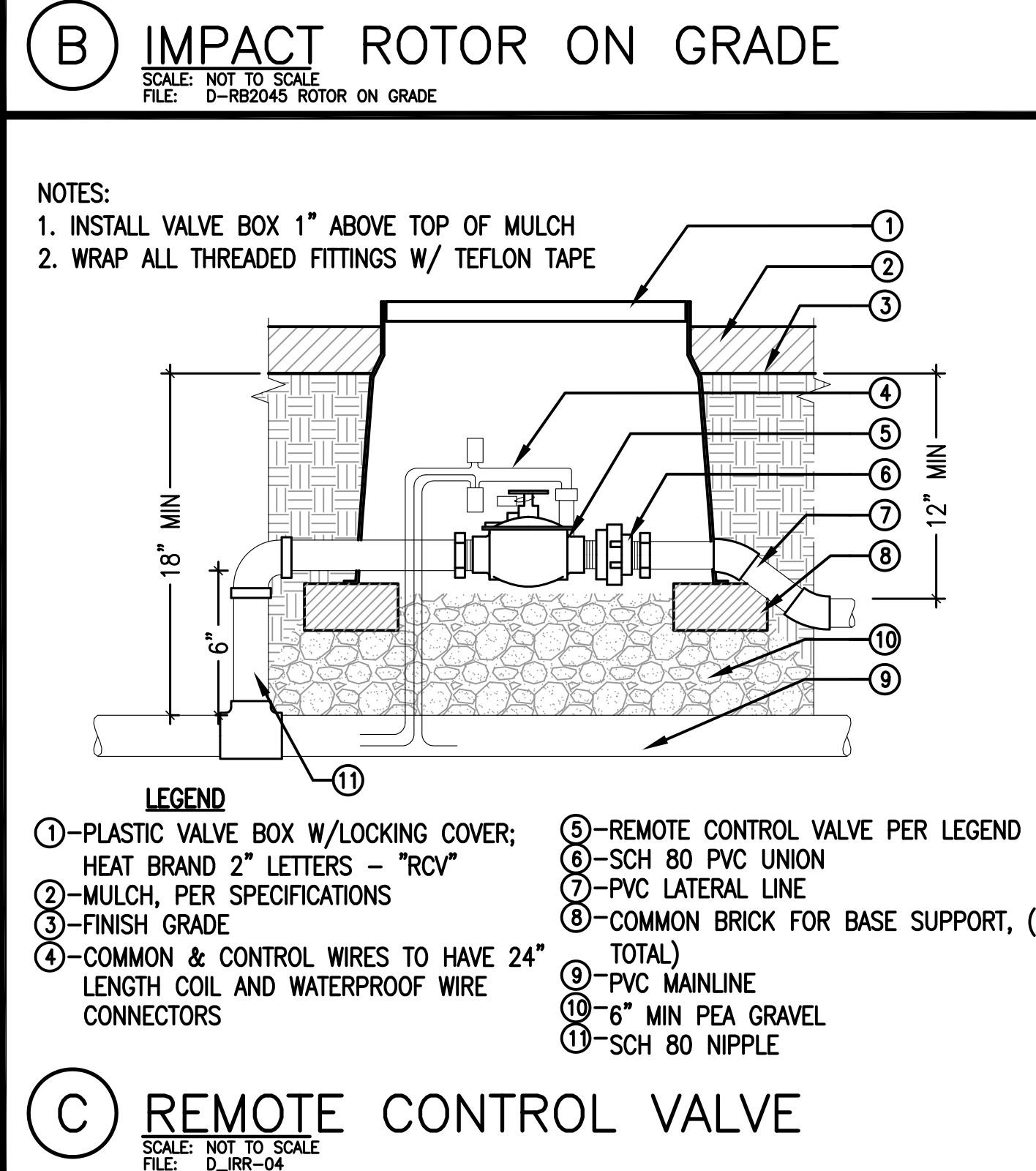
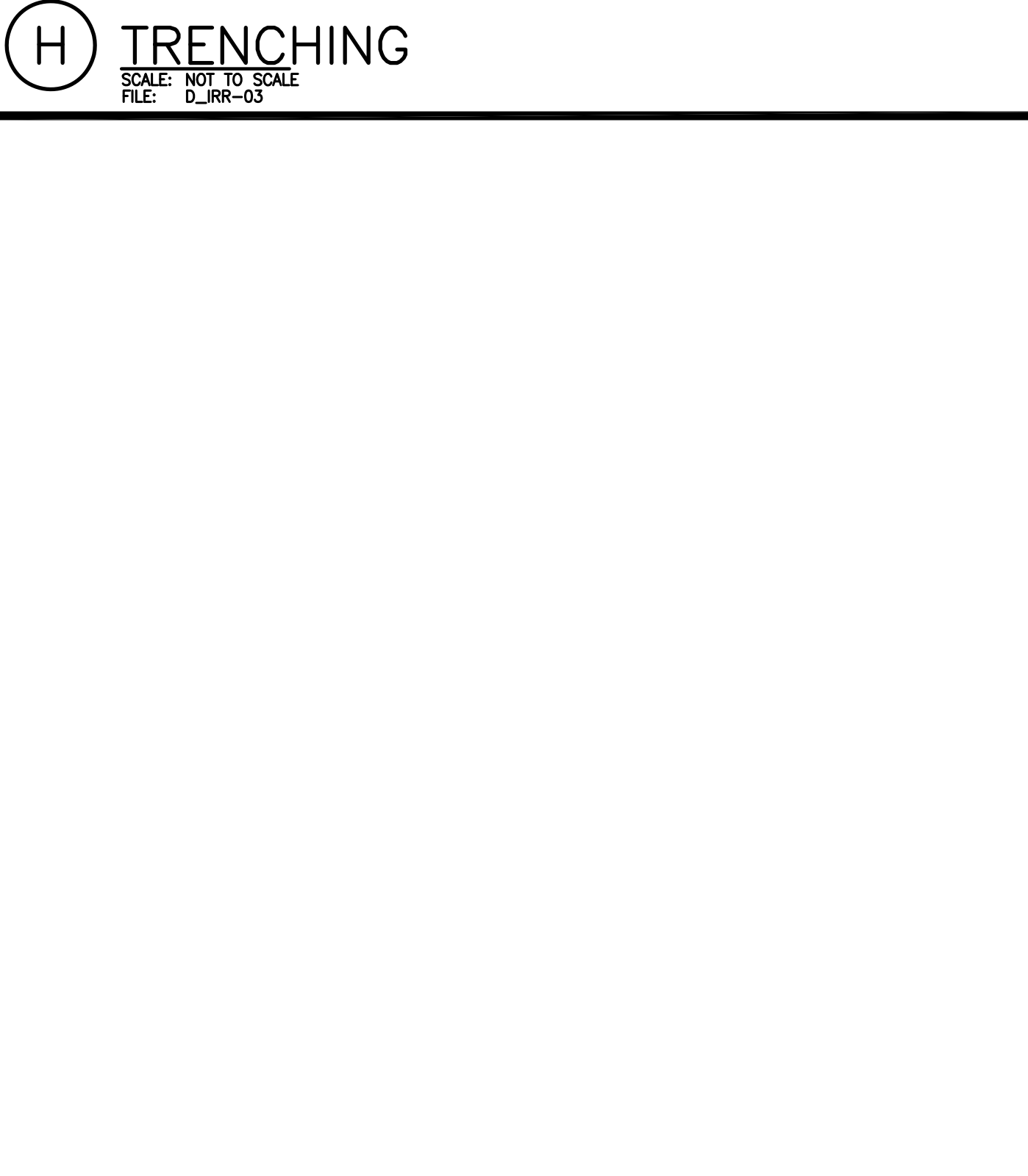
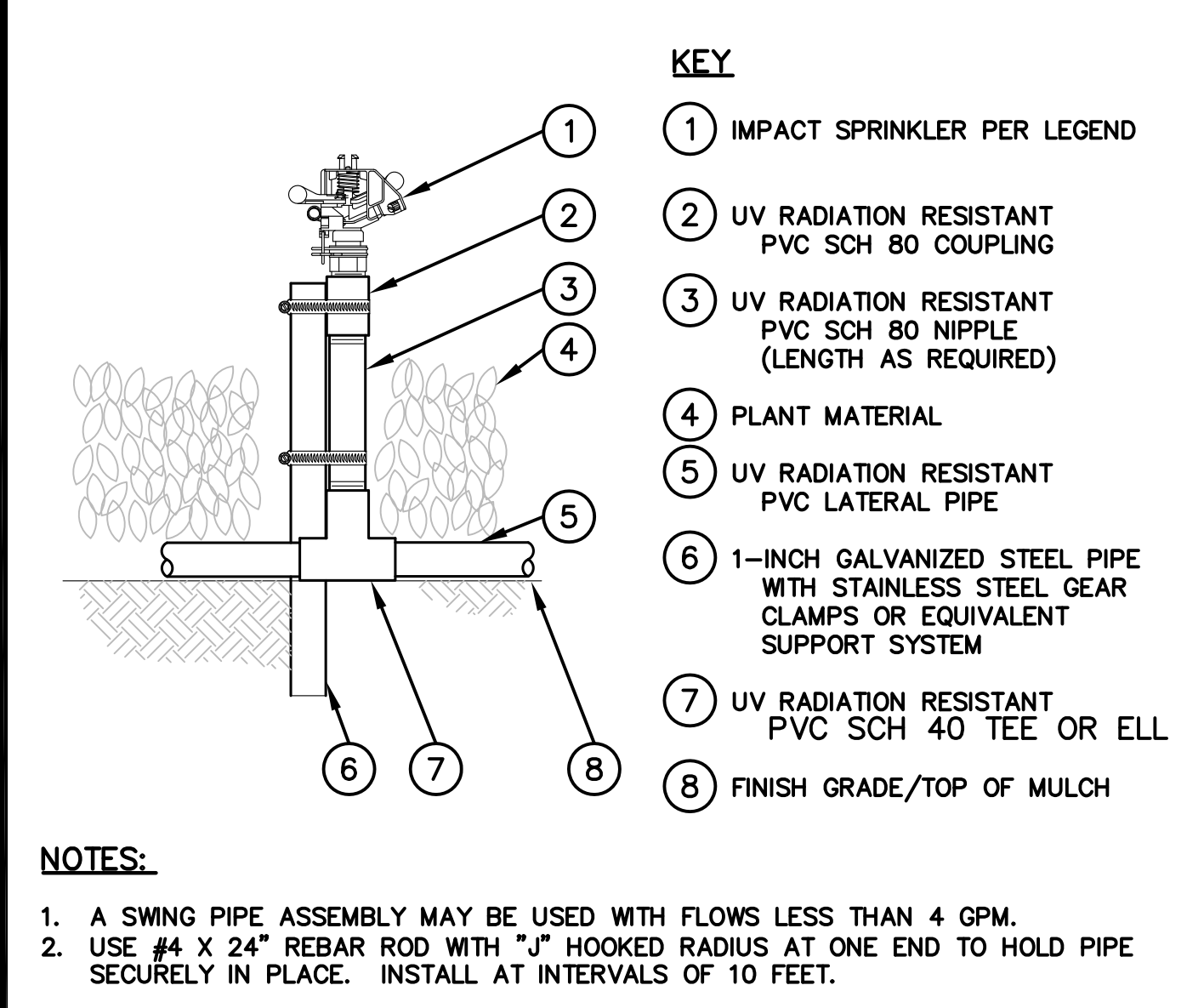
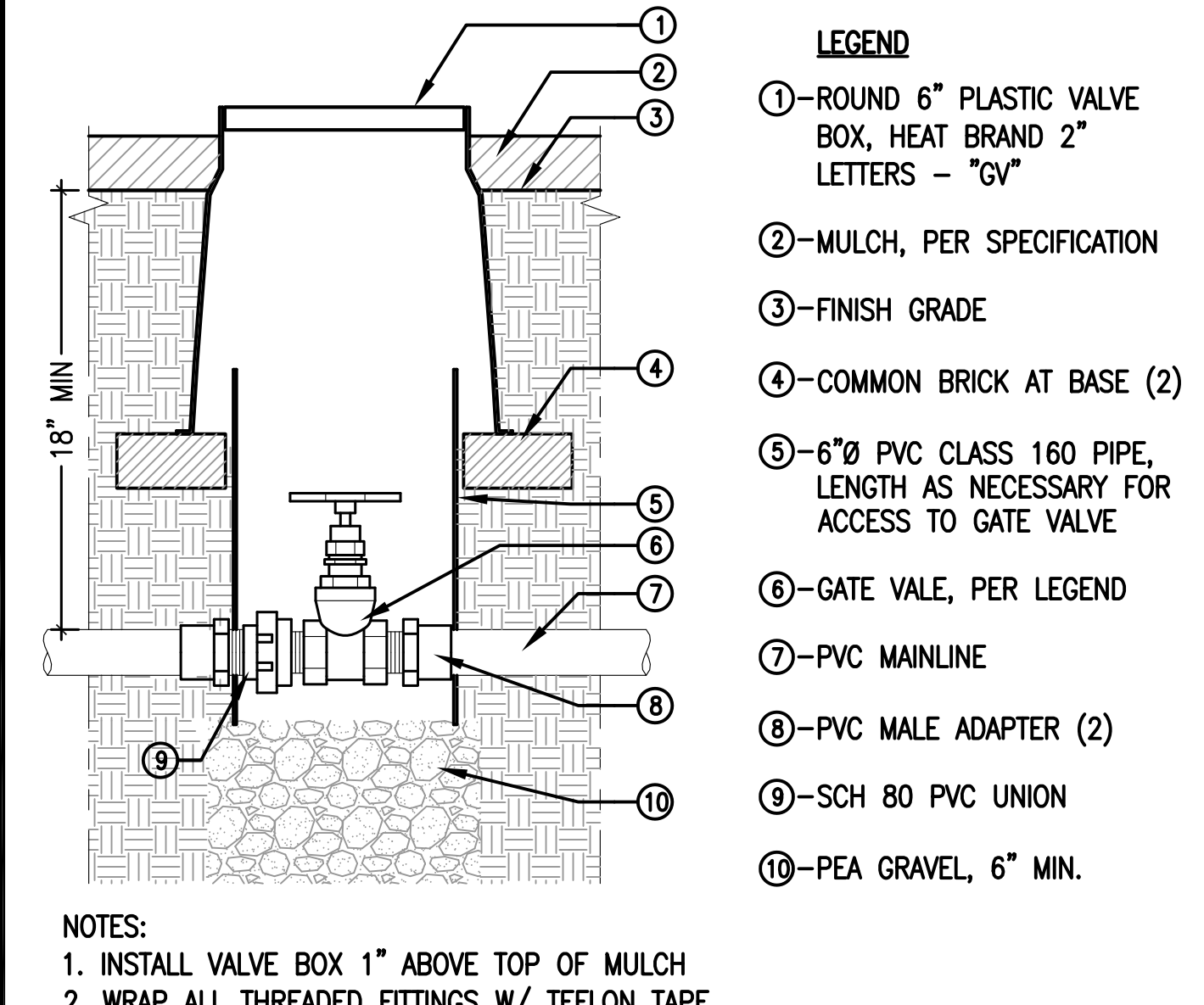
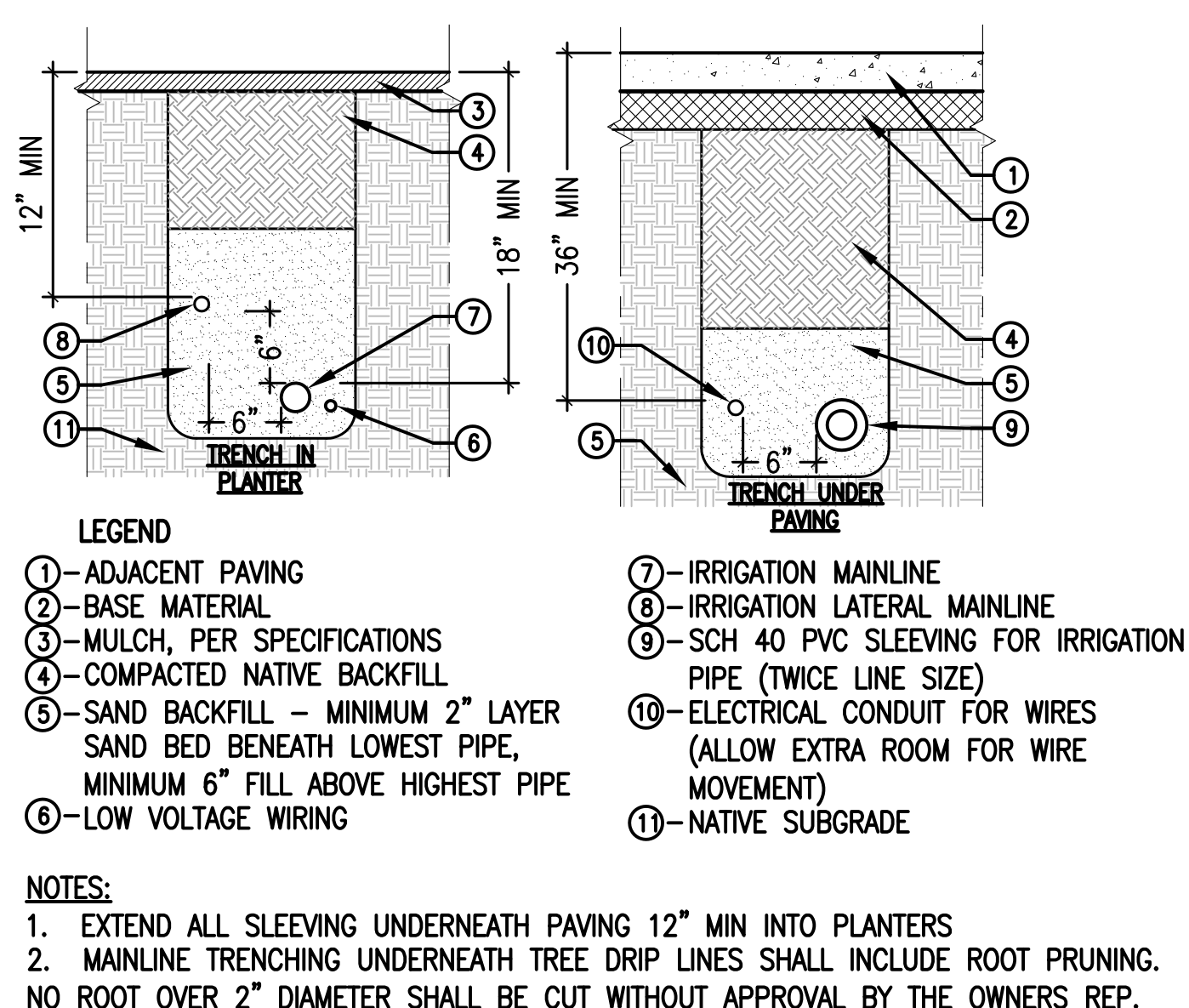
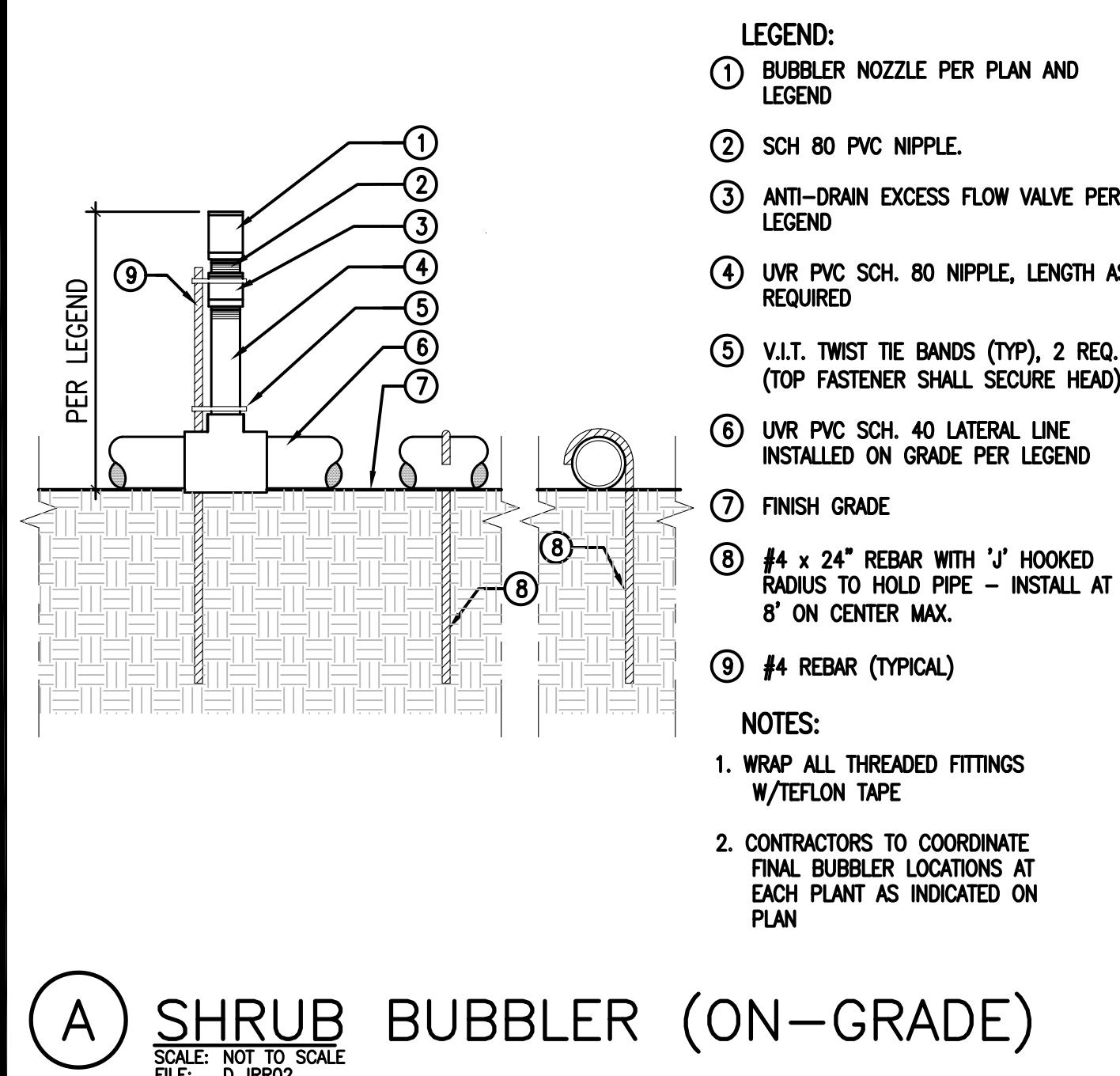
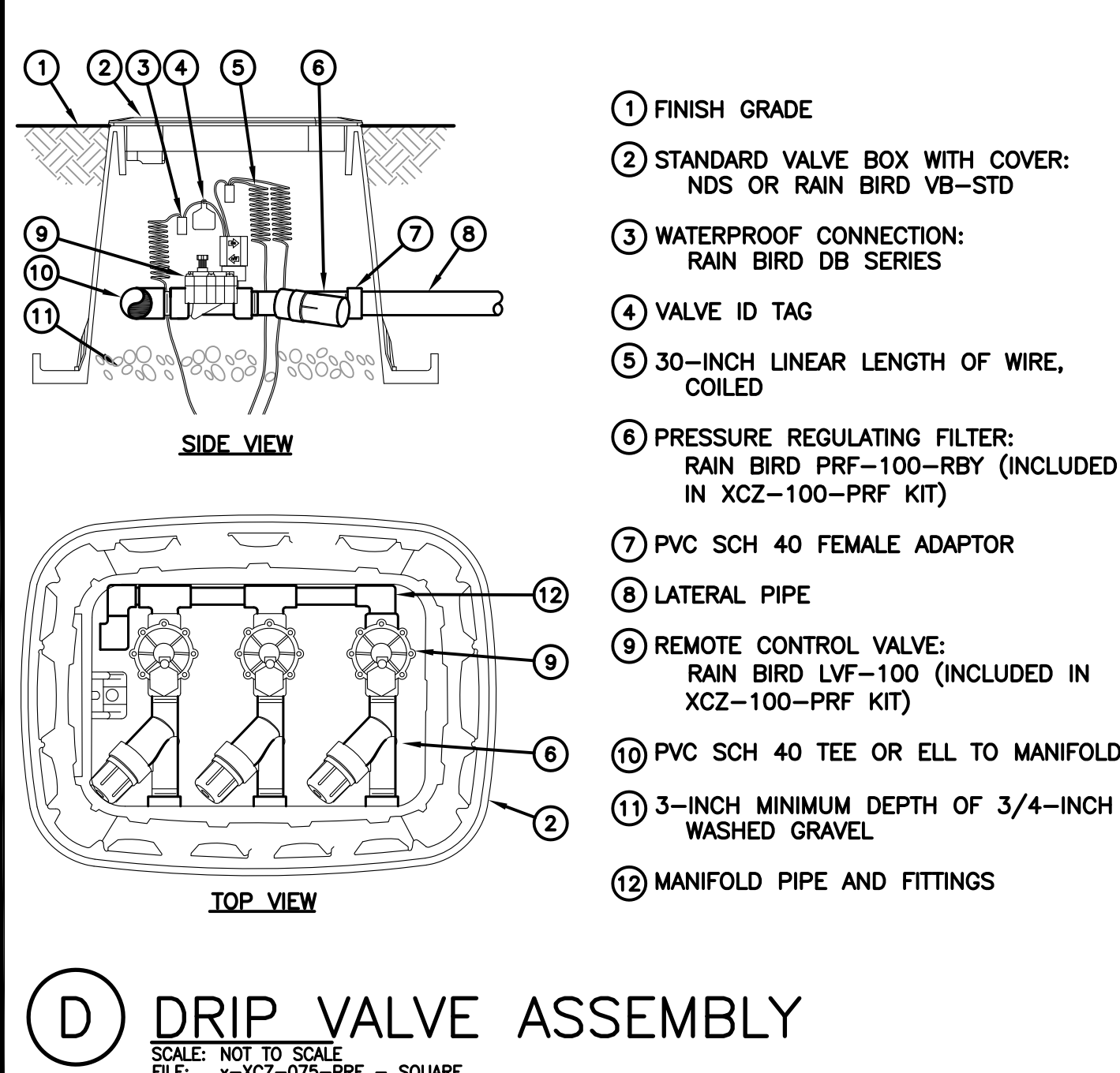
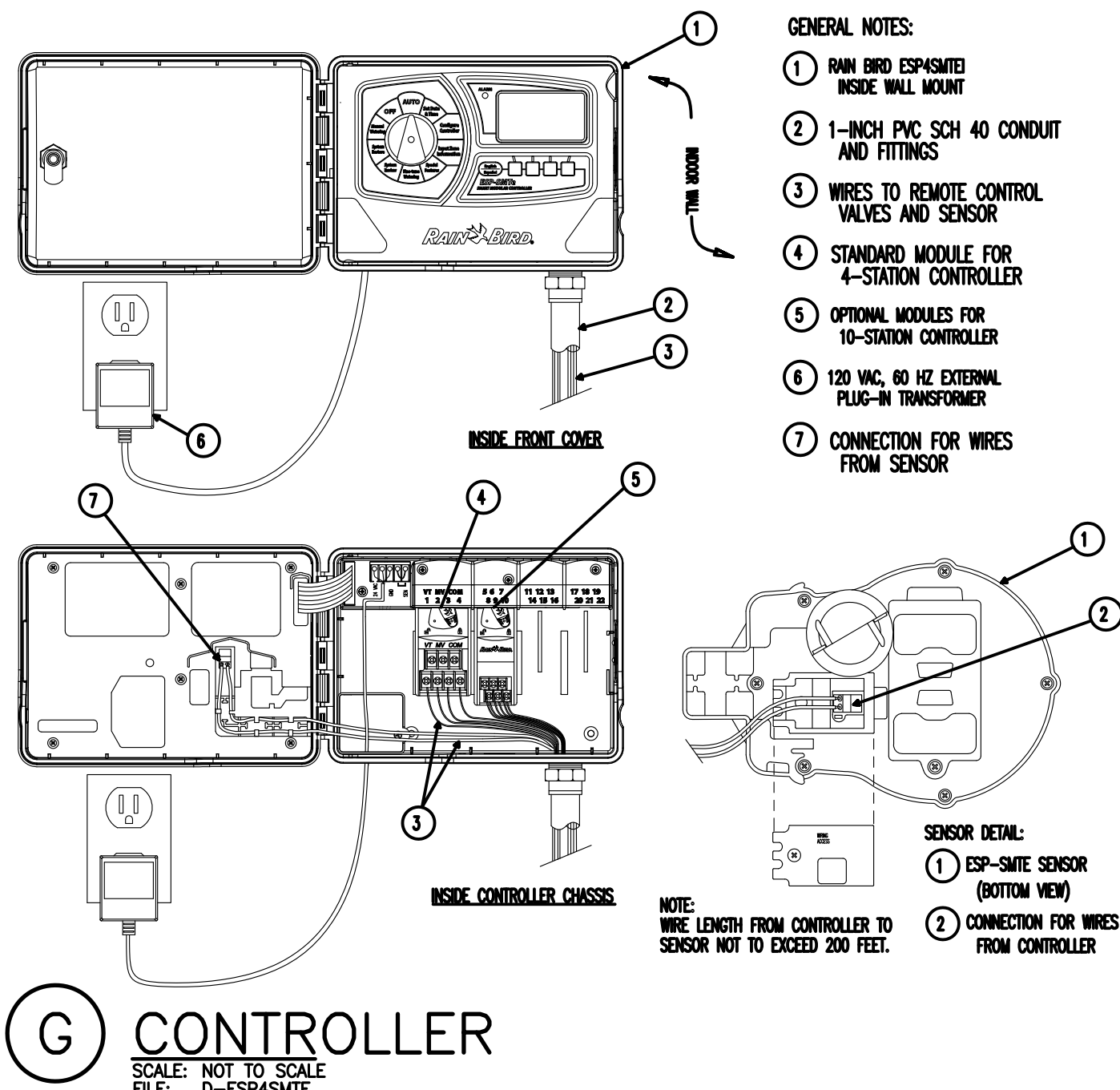

| REVISIONS | DATE |
|-----------|------|
| 1. | |
| 2. | |
| 3. | |
| 4. | |
| 5. | |
| 6. | |
| 7. | |
| 8. | |



DRAWING STATUS:
CONSTRUCTION DOCUMENTS

DRAWN BY: JWM
CHECKED BY:
PROJECT NO. 15-0313
DATE: 2016.06.01

SHEET CONTENTS:

IRRIGATION DETAILS

SHEET NUMBER:

L1.02

HYDROSEED SEED MIX

| SPECIES | PURE LIVE SEED LBS/ACRE |
|----------------------|-------------------------|
| Festuca microstachys | 6.0 |
| Stipa pulchera | 20.0 |
| Melica imperfecta | 2.0 |
| Agrostis pallens | 3.0 |
| Festuca idahoensis | 6.0 |
| Poa secunda | 4.0 |

HYDROMULCH MATERIALS

| PRODUCT | APPLICATION RATE |
|---------------------------------------|----------------------|
| Hydro Blanket BFM | 3,000-4,000 lbs/acre |
| Hydropost Premium Compost | 1,000 lbs./acre |
| Biosol Forte 7-2-1 Organic Fertilizer | 800 lbs./acre |
| AM 120 Mycorrhizal inoculum | 60 lbs./acre |
| Tri-C Soluble Humate | 1 lb./acre |
| Seed mix as prescribed by S&S Seeds | |

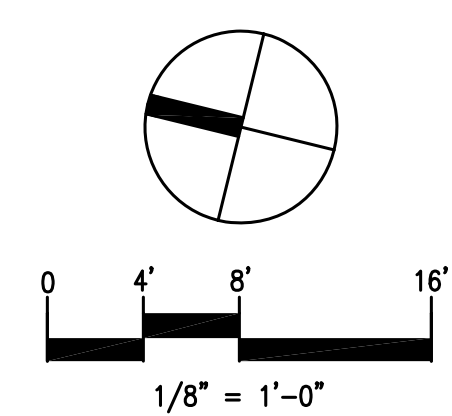
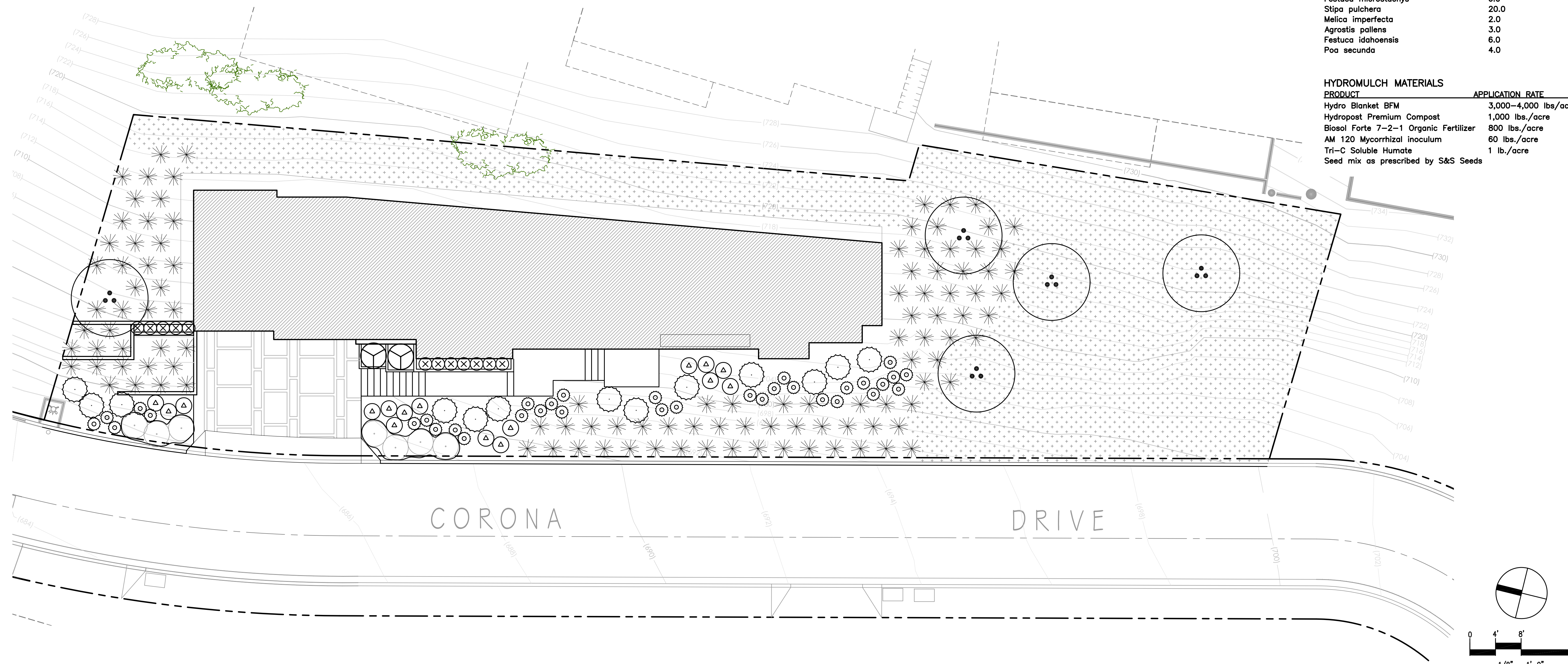

HYDROSEED NOTES

- HYDROSEED INSTALLER:** Contractor may subcontract with a California D-59 - Hydroseed Spraying Contractor for hydroseed operations. The Landscape Contractor shall be responsible for the quality of all labor and materials as provided by subcontractors and suppliers, including seed mix, hydroslurry ingredients, and their applications.
- NOTICE TO PROCEED:** Hydroseed shall be applied only after the completion and acceptance of the irrigation system installation and only after the completion and acceptance of weed eradication. All weeds will be cleared by the contractor prior to hydroseeding.
- SEED MIX:** The seed mix shall be used as listed in the Seed Mix List indicated on the plans, and shall be sourced by S&S Seeds (805-684-0436).
- HYDROMULCH:** The hydromulch shall contain all the ingredients as listed in the Hydromulch Ingredients list. No omissions or substitutions are permitted without prior authorization by the Owner's Representative. The Contractor shall provide invoices/purchase orders.
- STABILIZING EMULSION:** The hydromulch contains erosion control stabilizing emulsion with a functional longevity of 8-12 months. Application shall not occur during rainy weather or when soil temperature is below 40 degrees F. Pedestrians or equipment shall not be permitted to enter areas where mixtures containing stabilizing emulsion have been applied.
- GERMINATION STAGE IRRIGATION:** Commence watering one day after hydroseeding the planting areas. Water the area until the mulch fiber is moistened thoroughly. Do not saturate or wash the fiber or soil particles off the slopes. The contractor shall repair any hydroseed that erodes due to improper watering. Water the area with short and frequent cycles to maintain moisture content for maximum germination. At all times during operation, the irrigation system must be observed. Irrigation scheduling must be determined by air temperature, prevailing wind, soil texture, slope exposure, and other physical factors. It is imperative that the soil be kept moist at all times during the germination period. Irrigation may be supplemented with hand-watering if necessary to achieve equal coverage. The short, frequent watering cycles shall continue until the seedlings have grown beyond the germination stage.
- ESTABLISHMENT PERIOD IRRIGATION:** The irrigation frequency shall be reduced and the duration of cycles increased. The watering schedule shall take into account all physical factors, and shall approximate watering once a day through completion of the maintenance period.

PLANTING NOTES

- EXISTING CONDITIONS:** Contractor to verify all locations and conditions of site. Locate all existing utilities before construction begins. Coordinate all work with other trades.
- FINISH GRADE:** Finish Grades shall be those indicated on the Drawings or as may be controlled by existing installations. Grades not otherwise indicated shall be uniform, straight levels, with no abrupt changes in the surface. Finish elevations shall be 1-1/2" below paved surfaces, mow strips, and curbs. Provide positive drainage away from all foundations and structures, without low spots or pockets.
- PLANT MATERIAL:** Provide trees, shrubs, groundcovers, and vines of quantity, size, genus, species and variety shown and scheduled for landscape work and complying with recommendations and requirements of ANSI Z60.1 "American Standard for Nursery Stock." Provide healthy, vigorous stock, grown in a recognized nursery in accordance with good horticultural practice and free of disease, insects, etc., larvae, and defects such as girdling or bound roots, knots, sun-scald, injuries, abrasions or disfigurement.
- SUBSTITUTIONS:** Substitutions are not permitted without written approval from the Owner's Authorized Representative. Substituted plant material installed or furnished without prior approval may be rejected and the Contractor may be required to remove such materials from the site at his own expense.
- PLANT MATERIAL APPROVALS:** Before planting operations commence, all or a representative sampling of plant material shall be reviewed at the site by the Owner's Authorized Representative. Defective plants installed without such review shall be removed from the site upon request by the Owner's Representative and an acceptable plant substituted in its place. Provide two-week notice of plant arrival date of all plants prior to installation. Plant review will occur once (within span of one business day) for all plant material.
- LAYOUT:** Plant layout shall be inspected and approved by the Owner's Authorized Representative prior to installation. This inspection may occur simultaneous to the plant inspection day.
- ROOT SYSTEMS:** Contractor shall be responsible for inspection of all root systems on plant materials. Inspection shall include, but not be limited to, checking for rootbound stock, encircling roots at the perimeter of the container, girdling roots at the top surface of the rootball, and other defective root conditions. Such inspections shall include the complete removal of soil from one percent of plant material containers, or at least one plant from each nursery and each plant type. Contractor shall cut defective or potentially defective girdling, rootbound, and encircling roots and spread the root system into the surrounding backfill. The Contractor shall reject plants with excessively defective root systems.

- PRUNING:** Contractor shall do no pruning without the specific approval of the Owner's Representative. Plants pruned without approval shall be replaced by the Contractor, if required.
- SOIL TESTING AND SOIL AMENDMENT:** Contractor shall submit soil samples to a laboratory for analysis and amendment recommendations. Soil sampling to be conducted per laboratory protocol. Analysis shall include soil texture, infiltration rate, pH, soluble salts, sodium, percent organic matter, and recommendations for amendment. Contractor shall follow recommendations for soil amendment for the backfill mix for container plants and for turf and ground cover areas. Install Agriform or Best slow-release fertilizer tablets per manufacturer's recommendations. Tamp backfill mix under and around rootballs as necessary, do not over compact. For soils less than 6% organic matter in the top 6 inches of soil—except for hydroseeded slopes, compost at a rate of a minimum of four cubic yards per 1,000 square feet of permeable area shall be incorporated to a depth of six inches into the soil.
- FINISH GRADE RESTORATION:** Restore finish grades by hand raking. Dispose of excess subgrade soil.
- BASINS:** Construct basins as necessary to water plants. Remove basins from all plants under a permanent irrigation system prior to final inspection and finish grade the planting area. Basins for plants to be hand-watered shall remain in place. Basin bottoms shall drain to berm away from plant stem.
- WEED CONTROL TREATMENT:** Prior to applying mulch, all planted areas (excluding turf) shall be treated with Regal Ronstar or equivalent per the manufacturer's specifications for pre-emergent treatment.
- MULCH:** Place a three-inch (3") minimum layer of mulch in all exposed soil surfaces not exceeding 3:1 slope or where hydroseeding is designated; rake bark mulch top dress evenly to create a uniform surface and pull bark mulch top dress away from trunks or stalks of plants. Leave 18" bark-free collar around all tree trunks, 6" bark-free collar around shrubs.
- CLEANUP:** After completion of all operations, Contractor shall remove all trash, excess soil and other debris. All walks and pavement shall be swept and washed clean, leaving the entire area in a neat, orderly condition.
- GUARANTEE:** All shrub and groundcover materials shall be guaranteed to be in a healthy and thriving condition ninety (90) days after Final Acceptance. Guarantee of plant material is effective unless it can be proven, to the satisfaction of the Owner, that the unhealthy or non-thriving material is due to causes other than the Contractor's materials or workmanship. Replace all dead plants and plants not in vigorous condition immediately upon notification by Owner during Guarantee Period. Replaced plants shall be subsequently guaranteed by the contractor for an additional 90 days following date of replacement.

PLANT LEGEND

| TREES | SIZE | WATER |
|--|---------|-------|
| PROSOPIS GLANDULOSA - HONEY MESQUITE (MULTI-TRUNK) | 24" BOX | L |
| SHRUBS | SIZE | WATER |
| AGAVE AMERICANA - CENTURY PLANT | 15 GAL. | L |
| AGAVE ATTENUATA 'BLUE FLAME' - BLUE FLAME AGAVE | 5 GAL. | L |
| ALOE STRIATA - CORAL ALOE | 5 GAL. | L |
| DIANELLA REVOLUTA 'LITTLE REV' - LITTLE REV FLAX LILLY | 5 GAL. | L |
| MUHLENBERGIA RIGENS - DEER GRASS | 1 GAL. | L |
| LANTANA MONTEVIDENSIS 'WHITE LIGHTNING'-TRAILING LANTANA | 1 GAL. | L |
| PHORMIUM TENAX 'ATROPURPUREUM COMPACTUM' - NZ FLAX | 15 GAL. | L |
| HYDROSEED | SIZE | WATER |
| HYDROSEED, WITH SOIL STABILIZATION MATRIX (SEE HYDROSEED LIST) | | L |

"I HAVE COMPLIED WITH THE CRITERIA OF THE WATER EFFICIENT LANDSCAPE ORDINANCE AND APPLIED THEM FOR THE EFFICIENT USE OF WATER IN THE LANDSCAPE DESIGN PLAN"

| REVISIONS | DATE |
|-----------|------|
| 1. | |
| 2. | |
| 3. | |
| 4. | |
| 5. | |
| 6. | |
| 7. | |
| 8. | |



DRAWING STATUS:
CONSTRUCTION DOCUMENTS

DRAWN BY: JWM
CHECKED BY:
PROJECT NO. 15-0313
DATE: 2016.06.01

SHEET CONTENTS:

**PLANTING
PLAN**

SHEET NUMBER:

L2.01

| REVISIONS | DATE |
|-----------|------|
| 1. | |
| 2. | |
| 3. | |
| 4. | |
| 5. | |
| 6. | |
| 7. | |
| 8. | |



DRAWING STATUS:
CONSTRUCTION DOCUMENTS

DRAWN BY: JWM
CHECKED BY:
PROJECT NO. 15-0313
DATE: 2016.06.01

SHEET CONTENTS:

PLANTING DETAILS

SHEET NUMBER:

L2.02

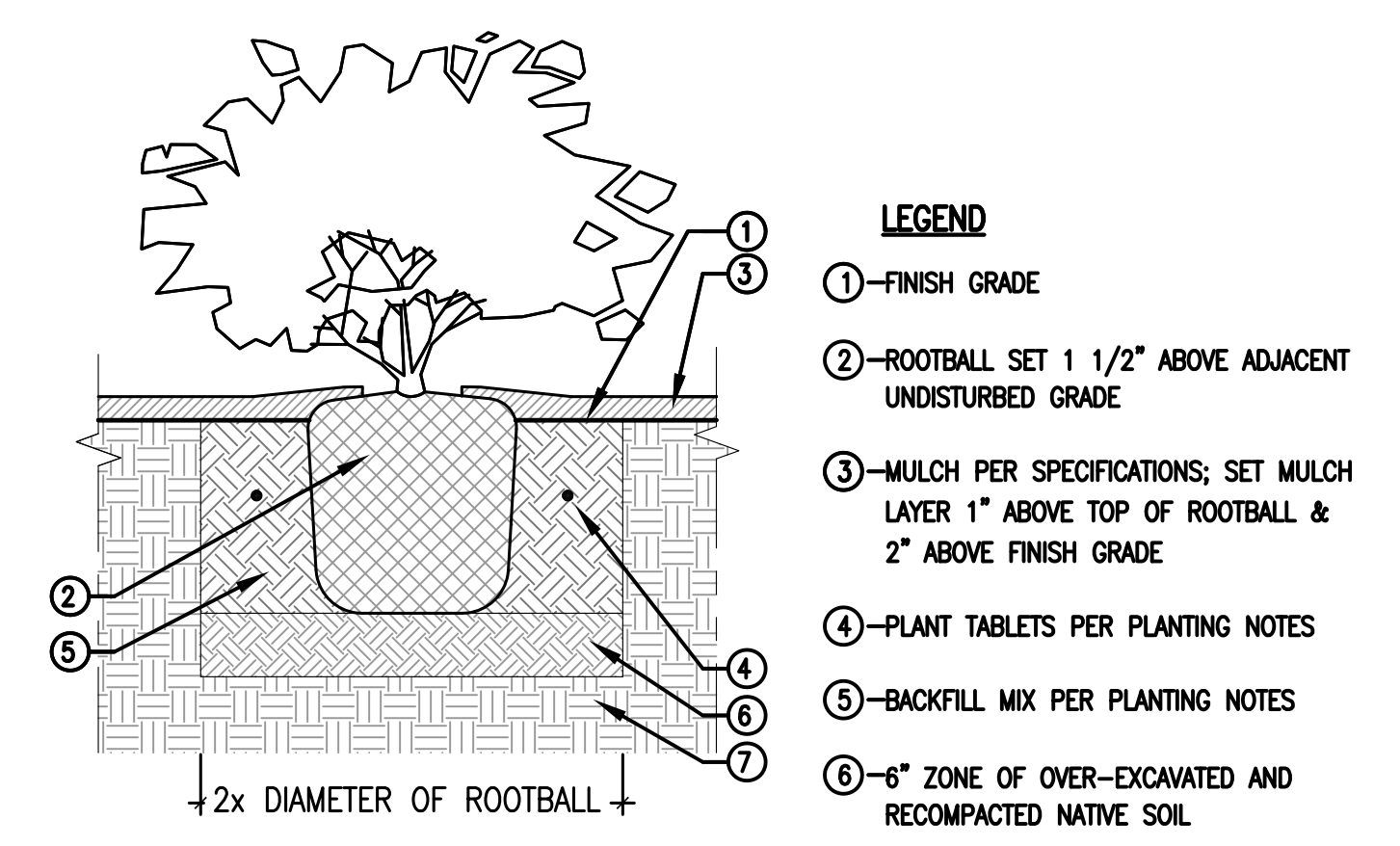

- LEGEND**
- ①—FINISH GRADE
 - ②—ROOTBALL SET 1 1/2" ABOVE ADJACENT UNDISTURBED GRADE
 - ③—MULCH PER SPECIFICATIONS; SET MULCH LAYER 1" ABOVE TOP OF ROOTBALL & 2" ABOVE FINISH GRADE
 - ④—PLANT TABLETS PER PLANTING NOTES
 - ⑤—BACKFILL MIX PER PLANTING NOTES
 - ⑥—6" ZONE OF OVER-EXCAVATED AND RECOMPACTED NATIVE SOIL
 - ⑦—NATIVE SUB-GRADE
- NOTES:**
1. KEEP MULCH 3" FROM STEM OF PLANT
 2. CONTRACTOR MAY BUILD WATERING BASINS DURING MAINTENANCE PERIOD, BUT MUST REMOVE BASINS AT PROJECT TURN-OVER

A SHRUB PLANTING
SCALE: NOT TO SCALE
FILE: D_PLA-01

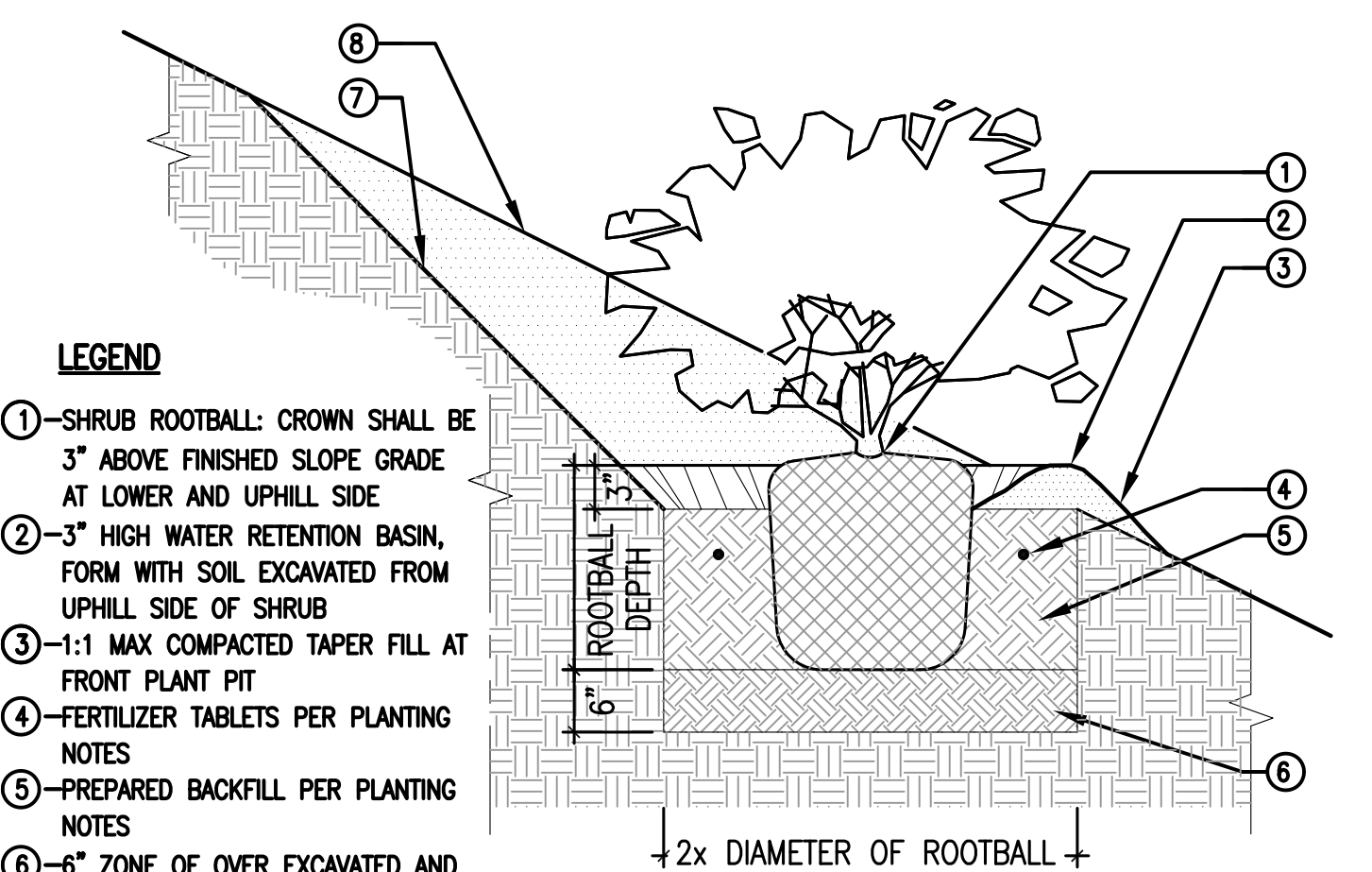

- LEGEND**
- ①—SHRUB ROOTBALL: CROWN SHALL BE 3" ABOVE FINISHED SLOPE GRADE AT LOWER AND UPHILL SIDE
 - ②—3" HIGH WATER RETENTION BASIN, FORM WITH SOIL EXCAVATED FROM UPHILL SIDE OF SHRUB
 - ③—1:1 MAX COMPACTED TAPER FILL AT FRONT PLANT PIT
 - ④—FERTILIZER TABLETS PER PLANTING NOTES
 - ⑤—PREPARED BACKFILL PER PLANTING NOTES
 - ⑥—6" ZONE OF OVER EXCAVATED AND RECOMPACTED NATIVE SOIL
 - ⑦—1:1 MAX CUT SLOPE BEHIND PLANT PIT
 - ⑧—EXISTING SLOPE
- NOTES:**
1. KEEP MULCH 3" FROM STEM OF PLANT
 2. CONTRACTOR MAY BUILD WATERING BASINS DURING MAINTENANCE PERIOD, BUT MUST REMOVE BASINS AT PROJECT TURN-OVER

B SHRUB PLANTING
SCALE: NOT TO SCALE
FILE: D_PLA-01

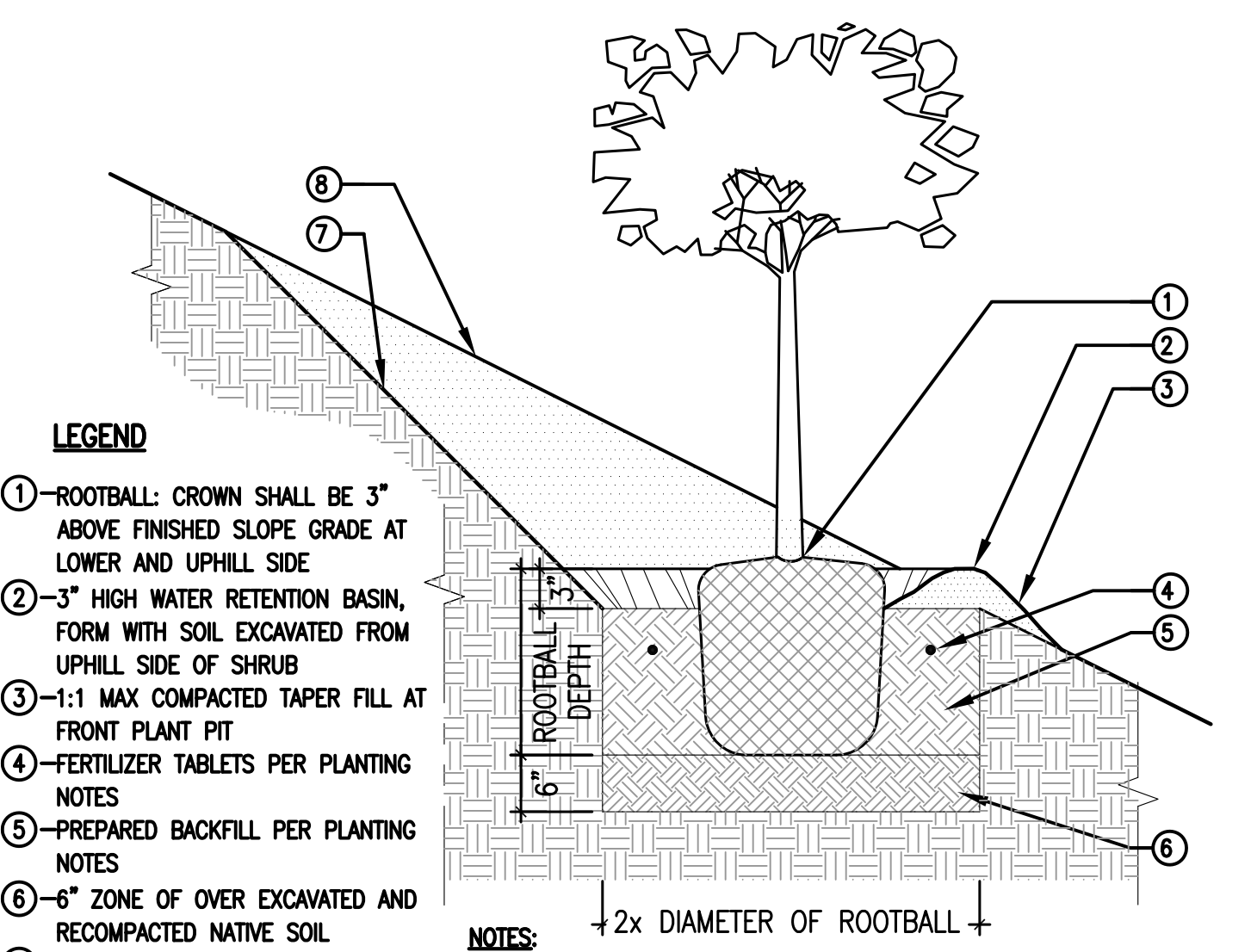

- LEGEND**
- ①—ROOTBALL: CROWN SHALL BE 3" ABOVE FINISHED SLOPE GRADE AT LOWER AND UPHILL SIDE
 - ②—3" HIGH WATER RETENTION BASIN, FORM WITH SOIL EXCAVATED FROM UPHILL SIDE OF SHRUB
 - ③—1:1 MAX COMPACTED TAPER FILL AT FRONT PLANT PIT
 - ④—FERTILIZER TABLETS PER PLANTING NOTES
 - ⑤—PREPARED BACKFILL PER PLANTING NOTES
 - ⑥—6" ZONE OF OVER EXCAVATED AND RECOMPACTED NATIVE SOIL
 - ⑦—1:1 MAX CUT SLOPE BEHIND PLANT PIT
 - ⑧—EXISTING SLOPE
- NOTES:**
1. KEEP MULCH 3" FROM STEM OF PLANT
 2. CONTRACTOR MAY BUILD WATERING BASINS DURING MAINTENANCE PERIOD, BUT MUST REMOVE BASINS AT PROJECT TURN-OVER

C TREE PLANTING ON SLOPE
SCALE: NOT TO SCALE
FILE: D_PLA-01

| | | |
|---|--|--|
| △ | | |
| △ | | |
| △ | | |

EC + Associates
 engineering
 8207 BROOKGREEN ROAD
 DOWNEY, CA 90240
 P: 562 708 3586 P: 562 714 2886

OWNER:
 MR. EDUARDO J. CARRILLO
 ADDRESS:
 8207 BROOKGREEN RD.
 DOWNEY, CA 90240

PROPOSED
 NEW 2-STORY HOUSE
 PROJECT ADDRESS:
 1246 CORONA DR. GLENDALE, CA 91205
 VACANT LAND,
 GLENDALE CA 91205

CHECK AND VERIFY ALL
 DIMENSIONS BEFORE
 PROCEEDING WITH THE
 WORK. REPORT
 DISCREPANCIES TO THE
 ENGINEER. ALL
 CONSTRUCTION SHALL
 CONFORM TO THE C.B.C.

TITLE
SITE PLAN

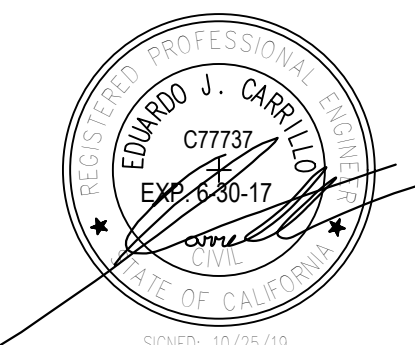

| | |
|----------------|----------|
| JOB #: | DRAWN: |
| 15-000 | E.C. |
| DATE: | CHECKED: |
| 12 / 22 / 2016 | E.C. |

A-1.1
 SHEET OF

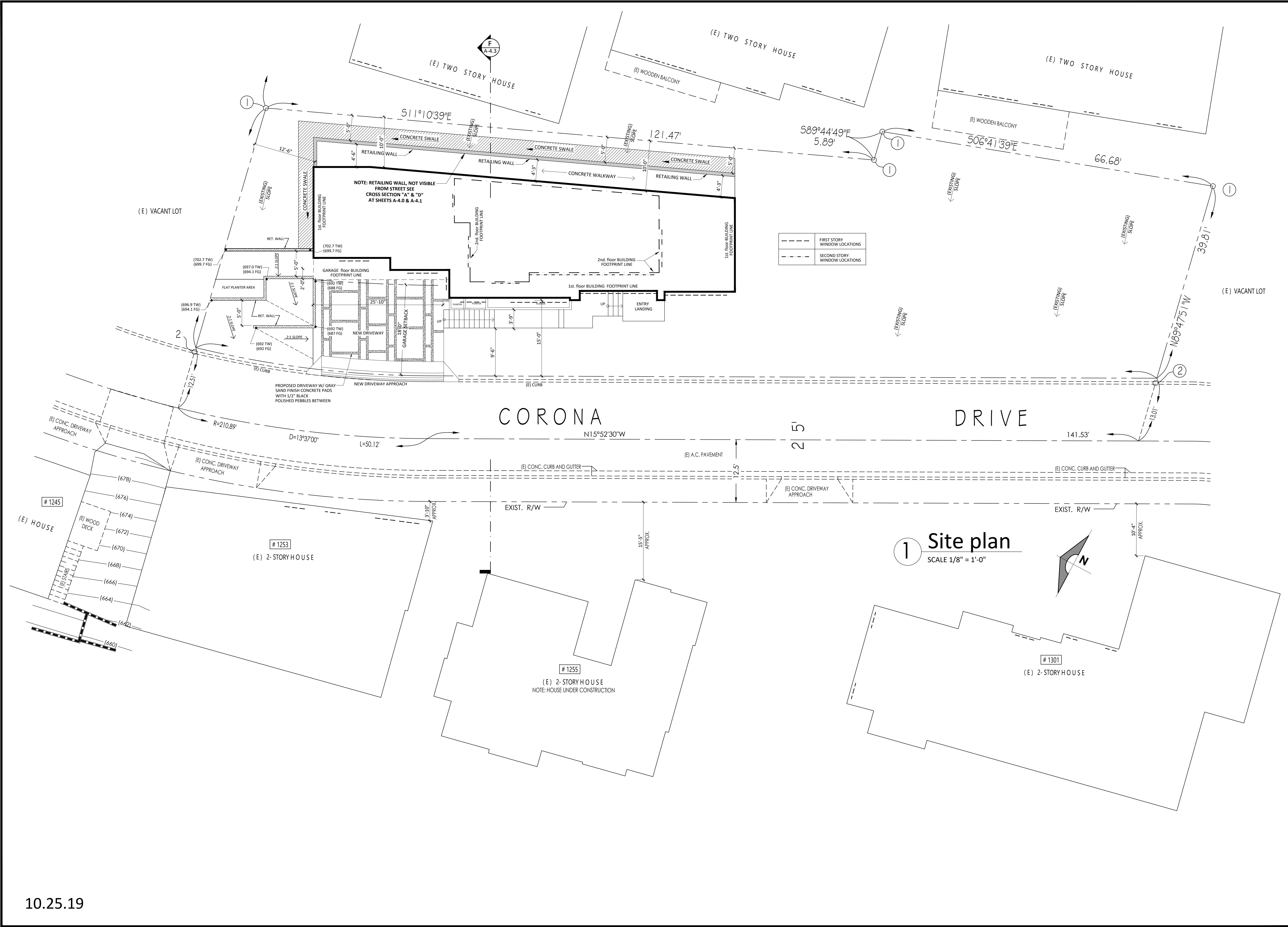

Cut/Fill Report

Generated: 2019-12-30 11:24:47
 By user: David Cervantes
 Drawing: J:\2019 Projects\jn198-1248 Corona ave\Drawings\Xref\J:\2019 Projects\jn198-1248 Corona ave\Drawings\Xref\X_TOPO.dwg

| Volume Summary | | | | | | | |
|---------------------|------|------------|-------------|-------------------|---------------|----------------|---------------|
| Name | Type | Cut Factor | Fill Factor | 2d Area (Sq. Ft.) | Cut (Cu. Yd.) | Fill (Cu. Yd.) | Net (Cu. Yd.) |
| Retaining Wall (1) | full | 1.000 | 1.000 | 434.68 | 46.98 | 0.07 | 46.91<Cut> |
| First Floor Pad (1) | full | 1.000 | 1.000 | 1838.70 | 445.56 | 38.83 | 406.73<Cut> |
| Driveway (1) | full | 1.000 | 1.000 | 515.97 | 61.48 | 1.08 | 60.40<Cut> |
| Garage Pad (1) | full | 1.000 | 1.000 | 837.66 | 544.46 | 0.00 | 544.46<Cut> |
| Totals | | | | | | | |
| | | | | 3627.02 | 1098.47 | 39.98 | 1058.49<Cut> |

* Value adjusted by cut or fill factor other than 1.0

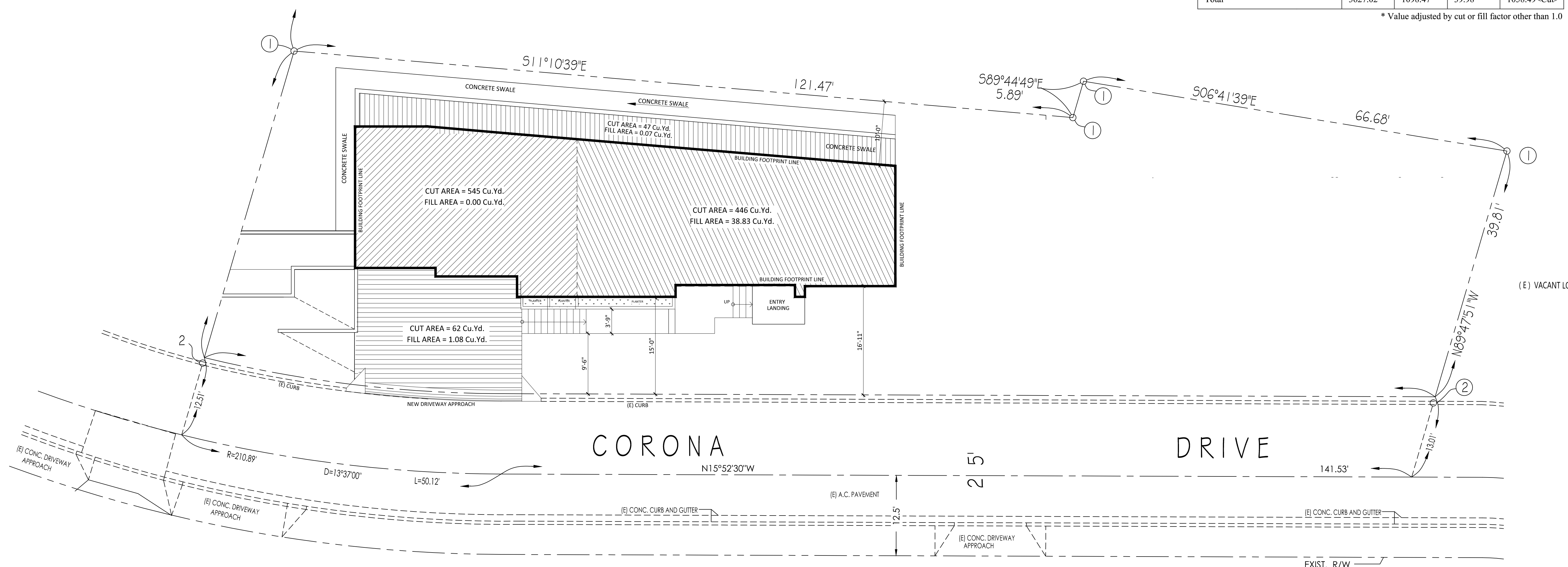

1 Site plan (CUT AREA)
 SCALE 1/8" = 1'-0"

TOTAL CUT AREA=..... 1,098.47 Cu. Yd.
 TOTAL FILL AREA=.....39.98 Cu. Yd.
 TOTAL NET =.....1,058.49 Cu. Yd (cut)

EC + Associates
 engineering
 8207 BROOKGREEN ROAD
 DOWNEY, CA 90240
 P: 562 708 3586 P: 562 714 2886

OWNER:
 MR. EDUARDO J. CARRILLO
 ADDRESS:
 8207 BROOKGREEN RD.
 DOWNEY, CA 90240

PROPOSED
 NEW 2-STORY HOUSE
 PROJECT ADDRESS:
 1248 CORONA DR. GLENDALE, CA 91205
 VACANT LAND,
 GLENDALE CA 91205

CHECK AND VERIFY ALL DIMENSIONS BEFORE PROCEEDING WITH THE WORK. REPORT DISCREPANCIES TO THE ENGINEER. ALL CONSTRUCTION SHALL CONFORM TO THE C.B.C.

TITLE
 SITE PLAN
 (CUT AREA)

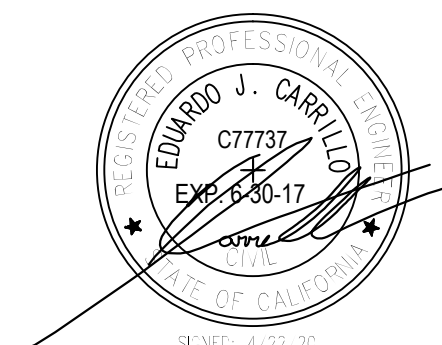

| | |
|-------------------------|------------------|
| JOB #: 15-000 | DRAWN: E.C. |
| DATE: 12 / 22 / 2019 | CHECKED: E.C. |

A-1.2
 SHEET OF

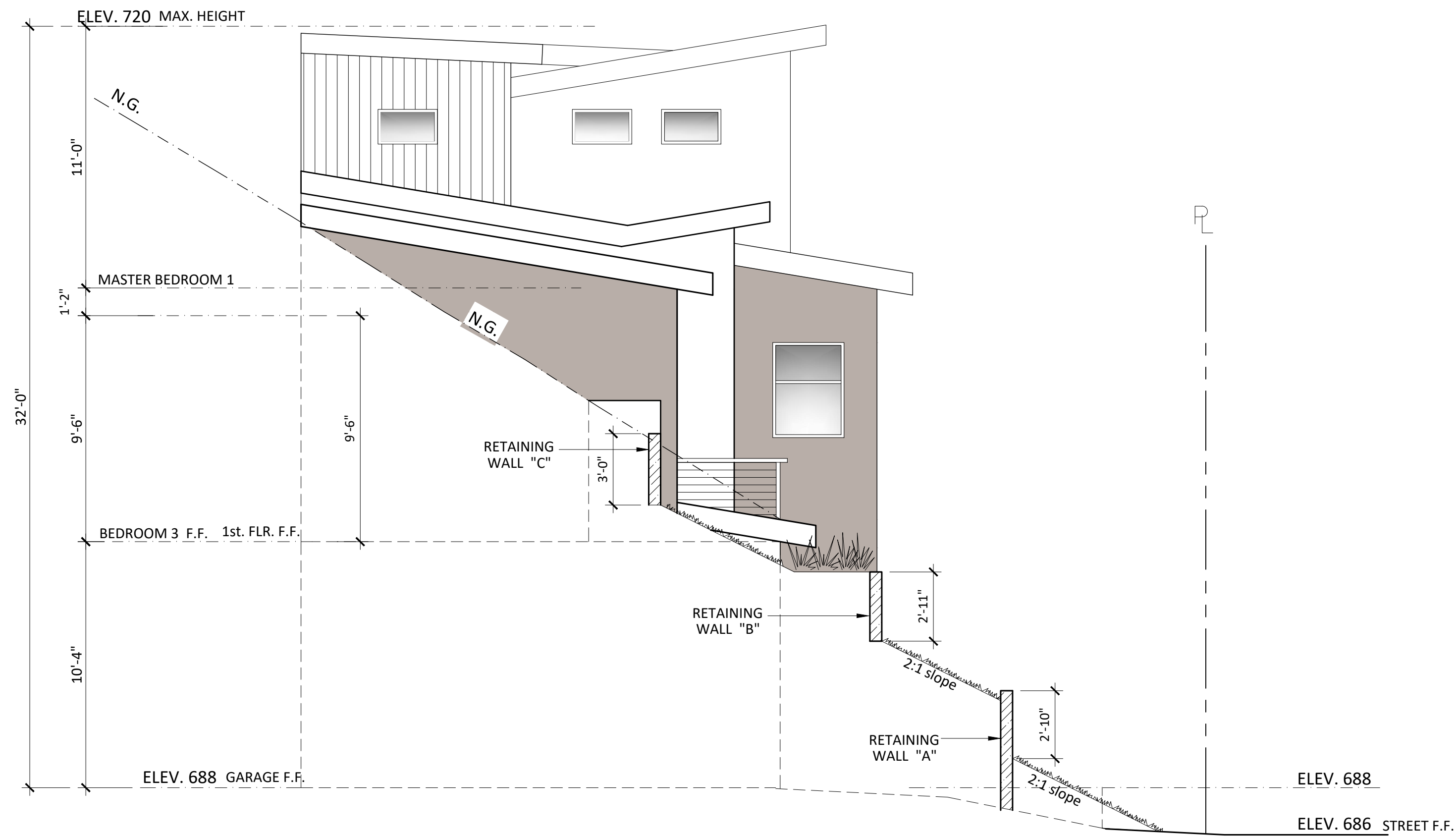

Retaining walls (Left side view)

SCALE 1/4" = 1'-0"

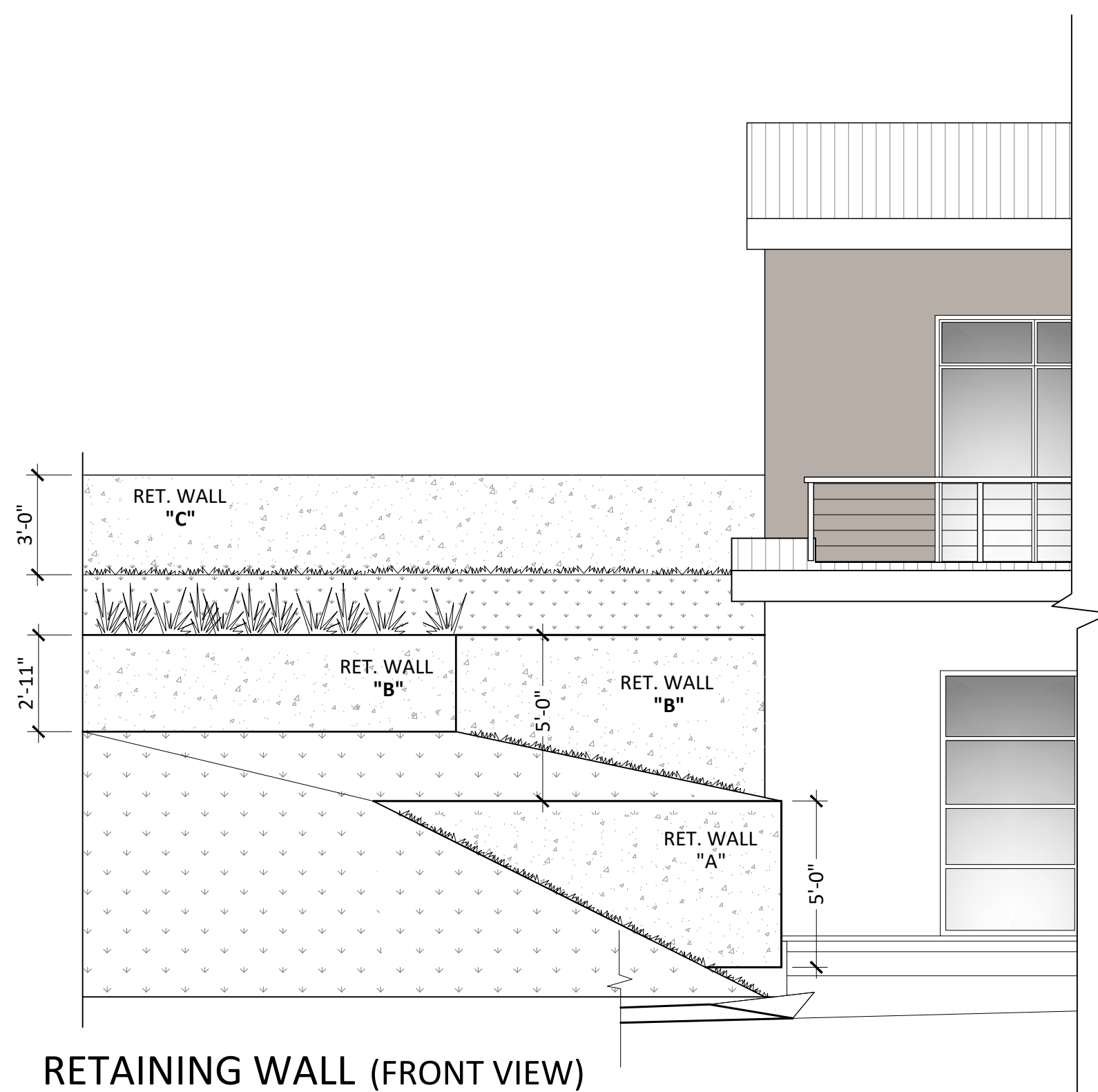

RETAINING WALL (FRONT VIEW)

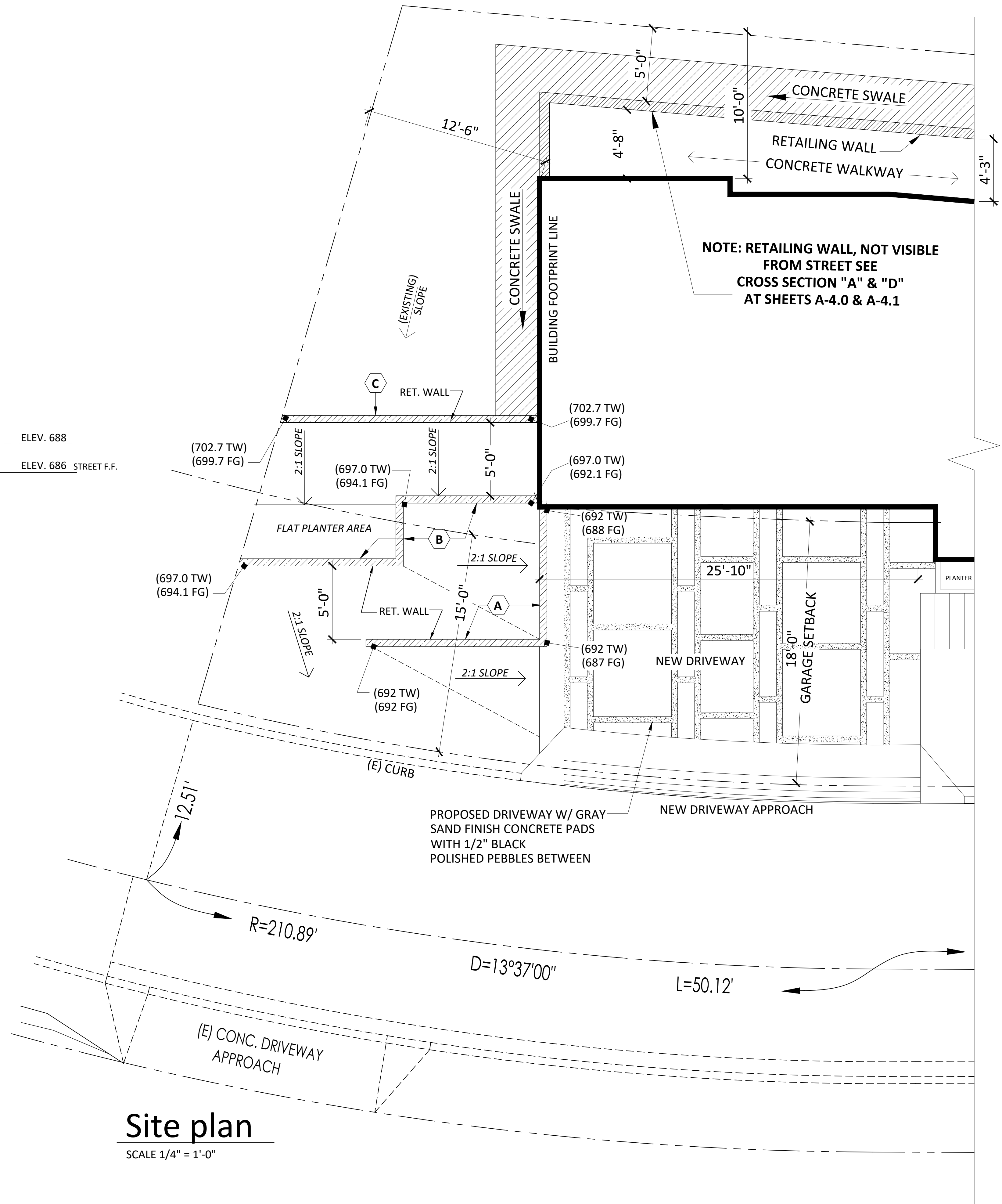

Site plan

SCALE 1/4" = 1'-0"

10.25.19

REVISION

MARK DATE REVISIONS

| | | |
|---|--|--|
| △ | | |
| △ | | |
| △ | | |

EC + Associates
engineering

8207 BROOKGREEN ROAD
DOWNEY, CA 90240
P: 562 708 3586 P: 562 714 2886

OWNER:
MR. EDUARDO J. CARRILLO

ADDRESS:
8207 BROOKGREEN RD.
DOWNEY, CA 90240

PROPOSED
NEW 2-STORY HOUSE

PROJECT ADDRESS:
1246 CORONA DR. GLENDALE, CA 91205
VACANT LAND,
GLENDALE CA 91205

CHECK AND VERIFY ALL DIMENSIONS BEFORE PROCEEDING WITH THE WORK. REPORT DISCREPANCIES TO THE ENGINEER. ALL CONSTRUCTION SHALL CONFORM TO THE C.B.C.

TITLE
RETAINING WALLS
PLAN &
ELEVATIONS

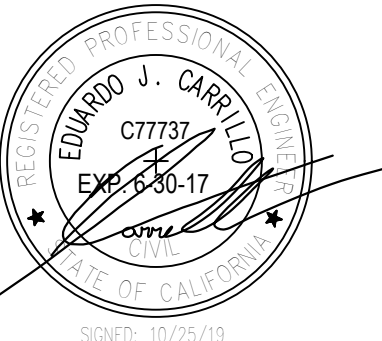

| | |
|-------------------------|------------------|
| JOB #: 15-000 | DRAWN: E.C. |
| DATE: 12 / 22 / 2016 | CHECKED: E.C. |

A-1.3
SHEET OF

| | | |
|---|--|--|
| △ | | |
| △ | | |
| △ | | |

EC + Associates
 engineering
 8207 BROOKGREEN ROAD
 DOWNEY, CA 90240
 P: 562 708 3586 P: 562 714 2886

OWNER:
 MR. EDUARDO J. CARRILLO
 ADDRESS:
 8207 BROOKGREEN RD.
 DOWNEY, CA 90240

PROPOSED
 NEW 2-STORY HOUSE
 PROJECT ADDRESS:
 1248 CORONA DR. GLENDALE, CA 91205
 VACANT LAND,
 GLENDALE CA 91205

CHECK AND VERIFY ALL
 DIMENSIONS BEFORE
 PROCEEDING WITH THE
 WORK. REPORT
 DISCREPANCIES TO THE
 ENGINEER. ALL
 CONSTRUCTION SHALL
 CONFORM TO THE C.B.C.

TITLE
GARAGE LEVEL

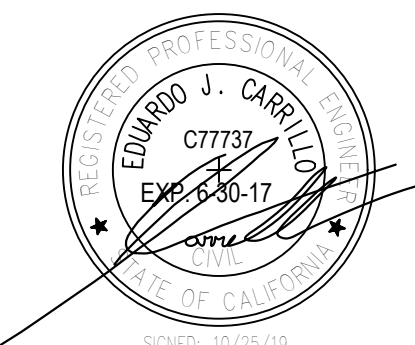

| | |
|----------------|----------|
| JOB #: | DRAWN: |
| 15-000 | E.C. |
| DATE: | CHECKED: |
| 12 / 22 / 2016 | E.C. |

A-2.0
 SHEET OF

| LEGEND | |
|--------|--|
| | CONCRETE WALLS (REFER TO STRUCTURAL PLANS FOR SPECIFICATIONS) |
| | NEW WALL CONSTRUCTION WITH 2x4 D.F. #2 AT 16" O.C. AND 2x6 STUDS AT 16" O.C. FOR PLUMBING WALLS |

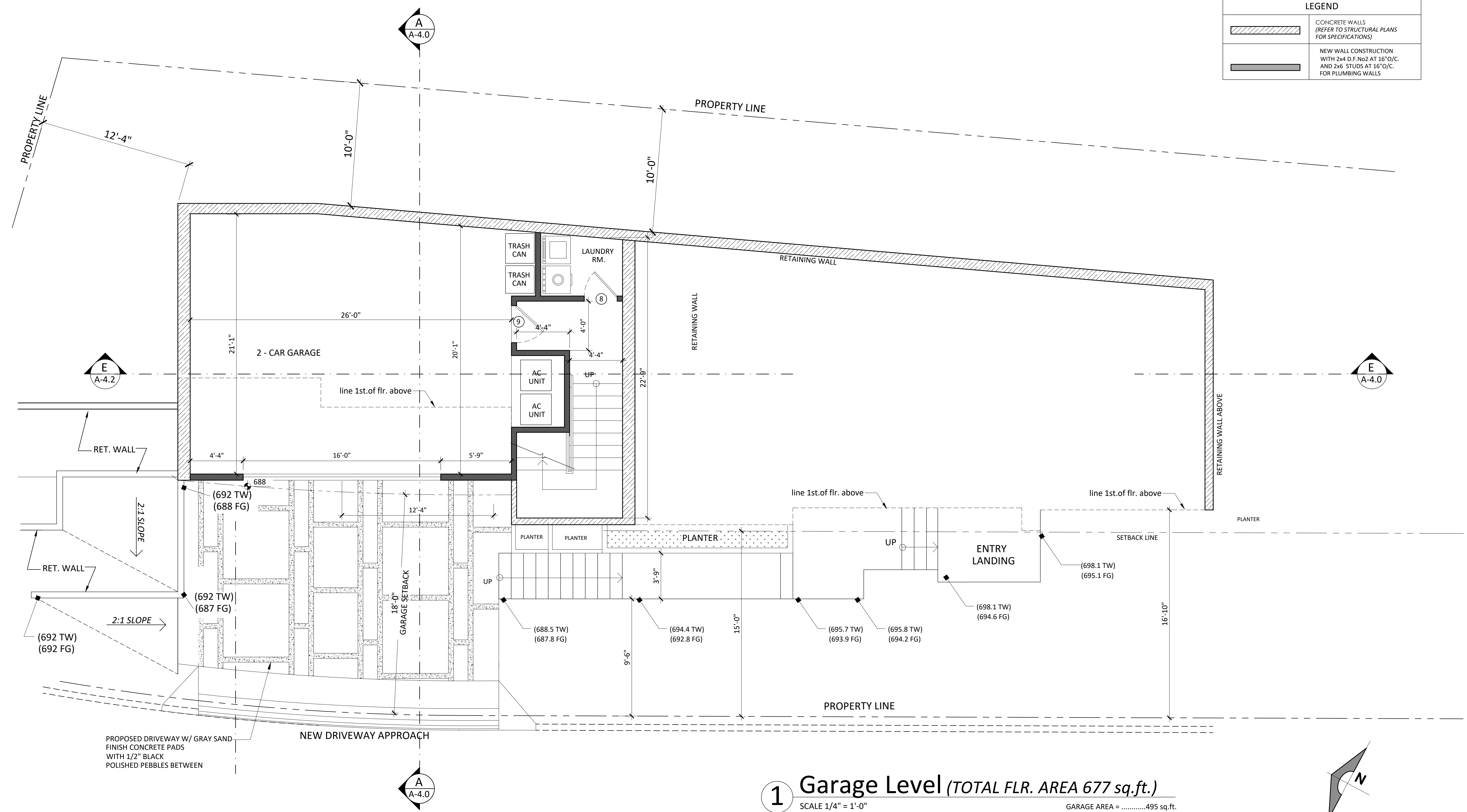

1 Garage Level (TOTAL FLR. AREA 677 sq.ft.)
 SCALE 1/4" = 1'-0"

GARAGE AREA =495 sq.ft.
 STAIRCASE AREA=120sq.ft.
 LAUNDRY ROOM =32 sq.ft.
 A.C. UNITS AREA=30 sq.ft.

10.25.19

PROPOSED DRIVEWAY W/ GRAY SAND
 FINISH CONCRETE PADS
 WITH 1/2" BLACK
 POLISHED PEBBLES BETWEEN

NEW DRIVEWAY APPROACH

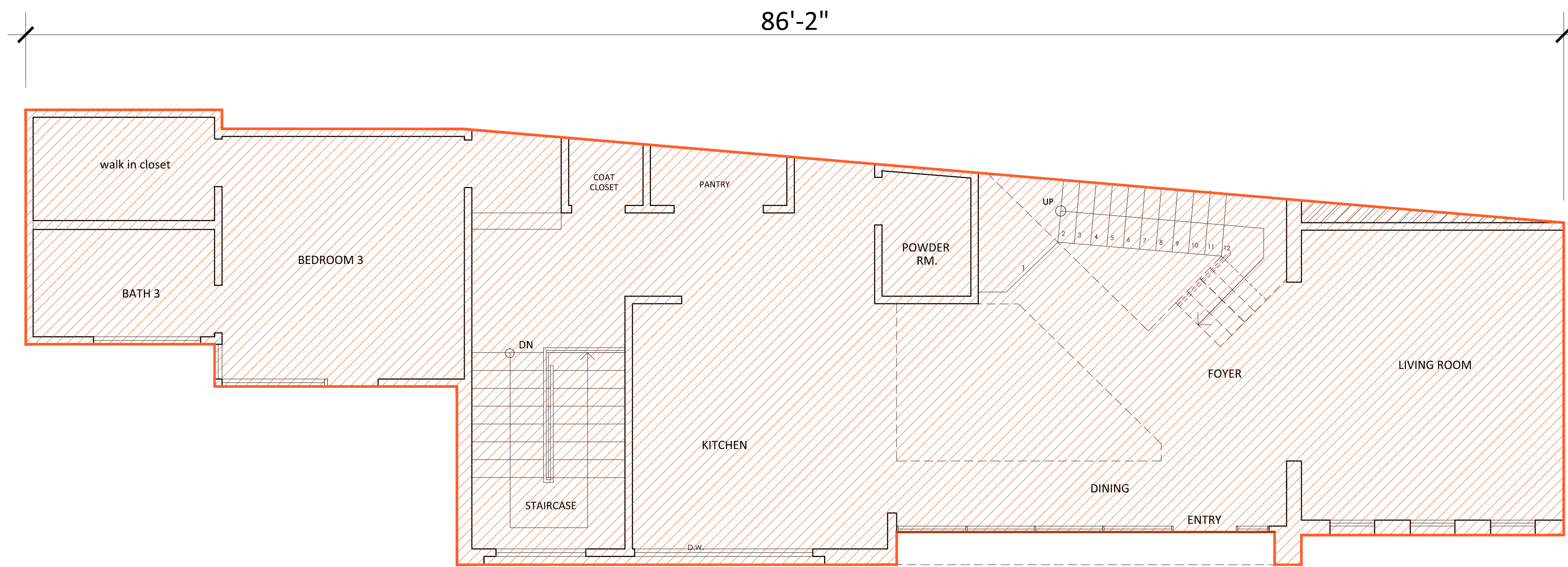

1st. SUBMITTAL 1st. FLOOR PLAN = 1,429 sq.ft.
FOR REFERENCE ONLY

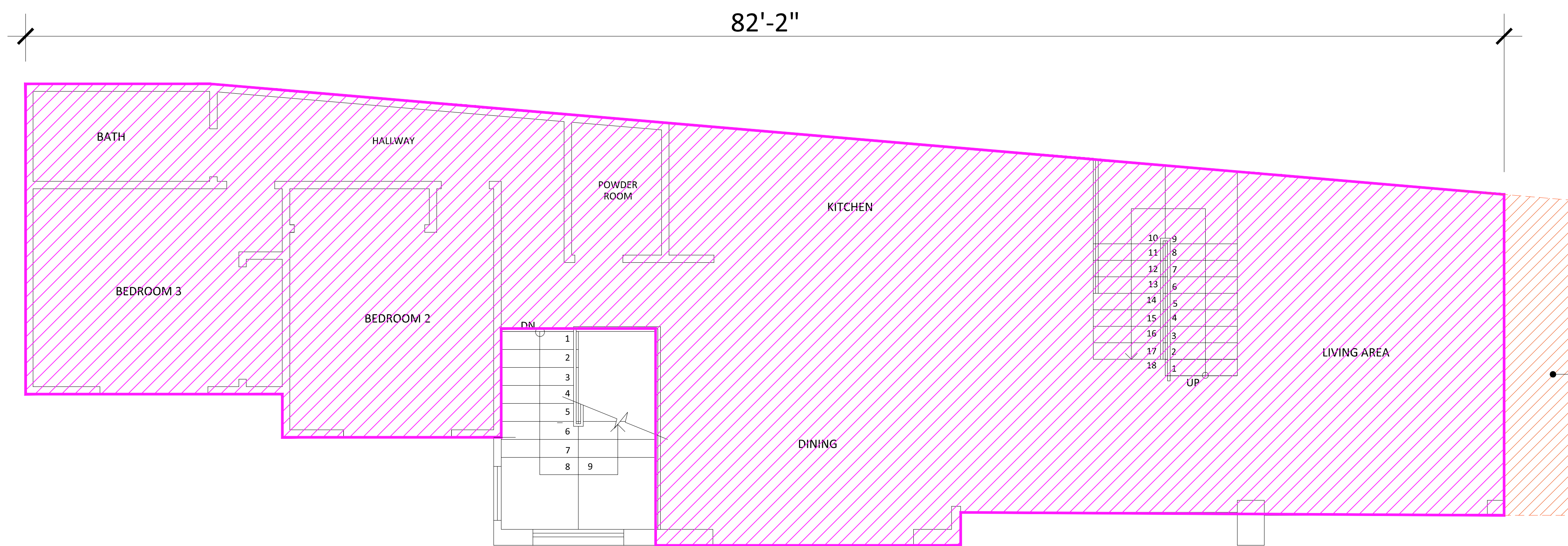

3rd. SUBMITTAL 1ST FLOOR PLAN = 1,537sq.ft.
CURRENT SUBMITTAL

AREA BEING
REMOVED
FROM 1st.
SUBMITTAL

04.20.20

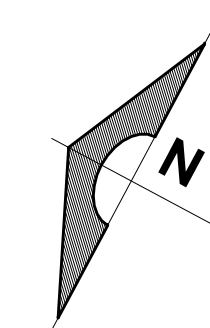

REVISION

MARK DATE REVISIONS



EC + Associates
e n g i n e e r i n g
8207 BROOKGREEN ROAD
DOWNEY, CA 90240
P: 562 708 3586 P: 562 714 2886

OWNER:
MR. EDUARDO J. CARRILLO
ADDRESS:
8207 BROOKGREEN RD.
DOWNEY, CA 90240

PROPOSED
NEW 2-STORY HOUSE

PROJECT ADDRESS:
1246 CORONA DR. GLENDALE, CA 91205
VACANT LAND,
GLENDALE CA 91205

CHECK AND VERIFY ALL
DIMENSIONS BEFORE
PROCEEDING WITH THE
WORK. REPORT
DISCREPANCIES TO THE
ENGINEER. ALL
CONSTRUCTION SHALL
CONFORM TO THE C.B.C.

TITLE

1st. submittal
FIRST FLOOR
AREAS

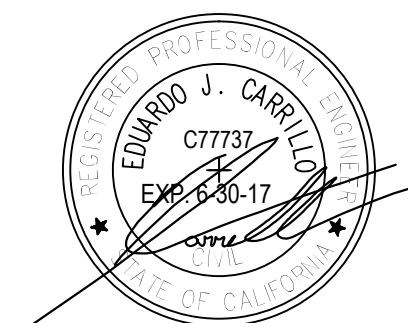

| | |
|-------------------------|------------------|
| JOB #: 15-000 | DRAWN: E.C. |
| DATE: 12 / 22 / 2016 | CHECKED: E.C. |

A-2.0c
SHEET OF

| REVISION | | |
|----------|------|-----------|
| MARK | DATE | REVISIONS |
| △ | | |
| △ | | |
| △ | | |

EC + Associates
 e n g i n e e r i n g
 8207 BROOKGREEN ROAD
 DOWNEY, CA 90240
 P: 562 708 3586 P: 562 714 2886

OWNER:
 MR. EDUARDO J. CARRILLO
 ADDRESS:
 8207 BROOKGREEN RD.
 DOWNEY, CA 90240

PROPOSED
 NEW 2-STORY HOUSE
 PROJECT ADDRESS:
 1246 CORONA DR. GLENDALE, CA 91205
 VACANT LAND,
 GLENDALE CA 91205

CHECK AND VERIFY ALL DIMENSIONS BEFORE PROCEEDING WITH THE WORK. REPORT DISCREPANCIES TO THE ENGINEER. ALL CONSTRUCTION SHALL CONFORM TO THE C.B.C.

TITLE
**1st. submittal
 SECOND FLOOR
 AREAS**

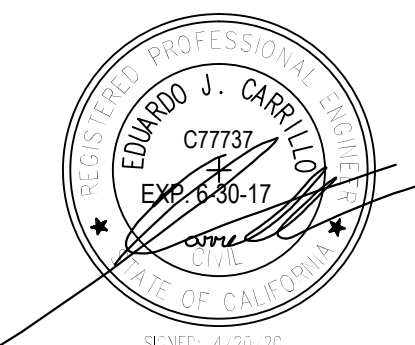

| | |
|-------------------------|------------------|
| JOB #: 15-000 | DRAWN: E.C. |
| DATE: 12 / 22 / 2016 | CHECKED: E.C. |

A-2.0d
 SHEET OF

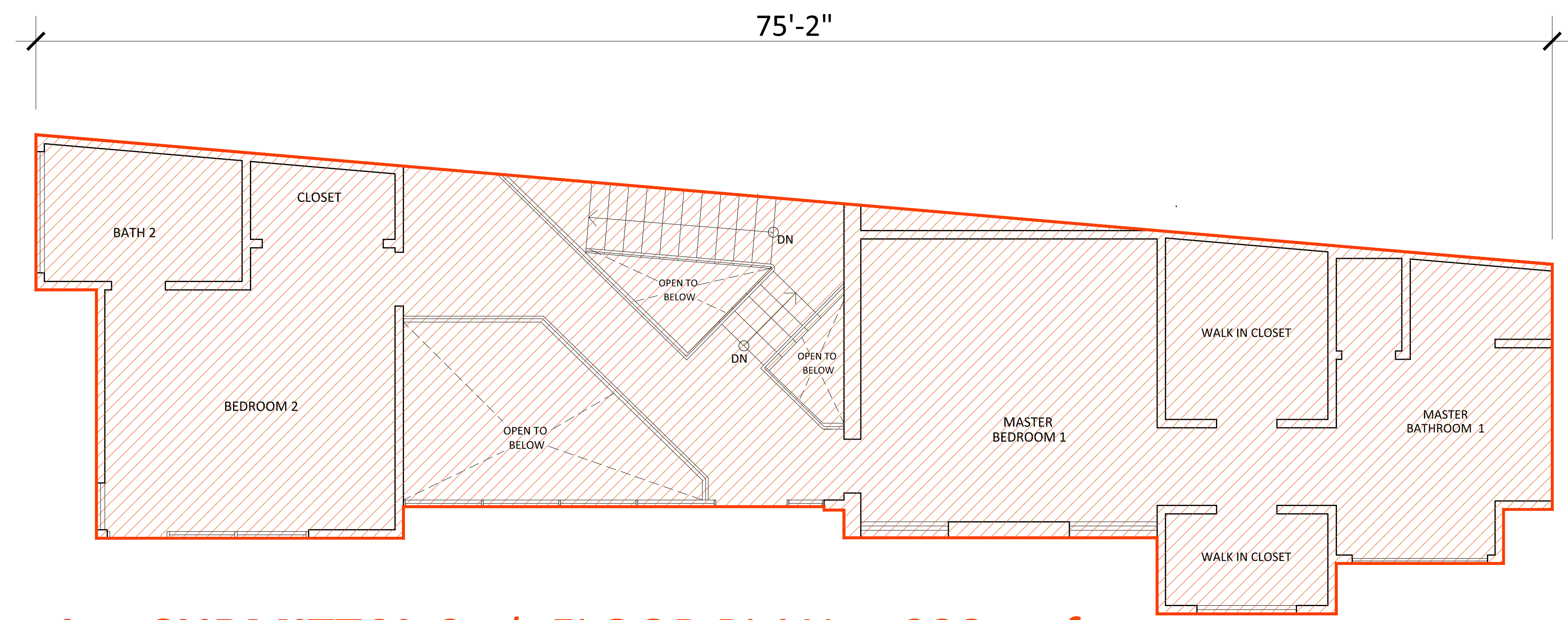

1st. SUBMITTAL 2nd. FLOOR PLAN = 938 sq.ft.
 FOR REFERENCE ONLY

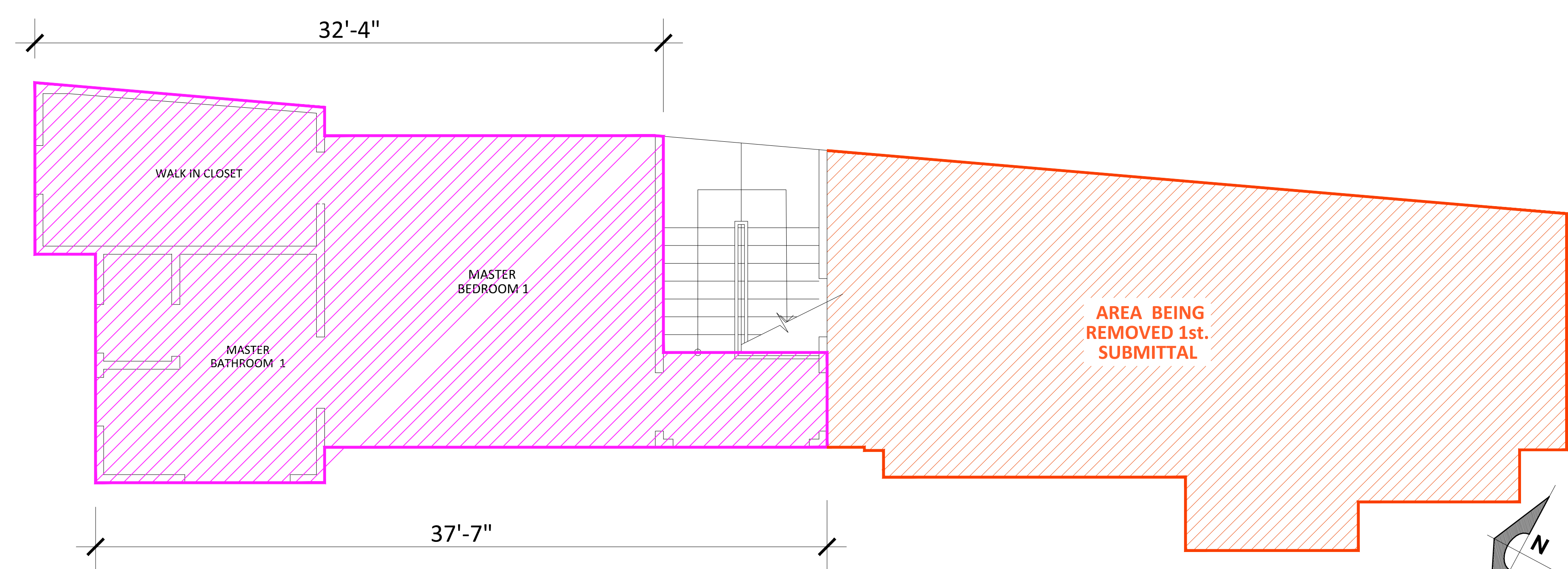

3rd. SUBMITTAL 2nd. FLOOR PLAN = 580 sq.ft.
 CURRENT SUBMITTAL

04.20.20

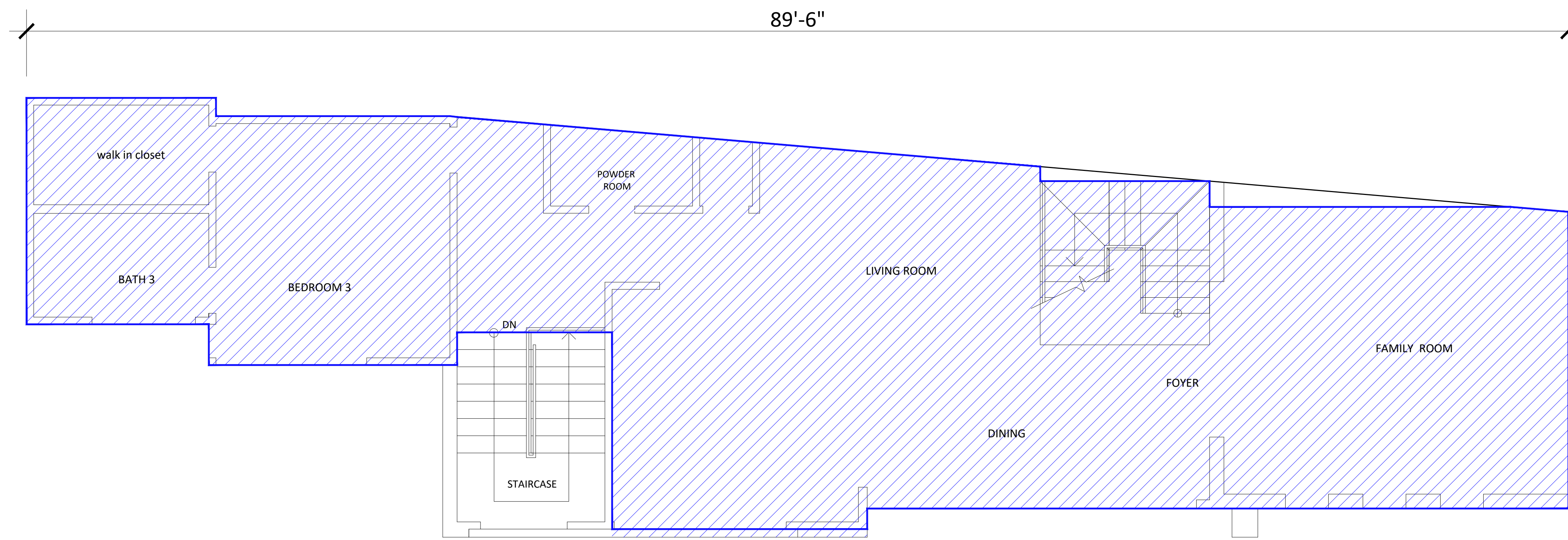

2ND SUBMITTAL 1ST FLOOR PLAN = 1,538 sq.ft.

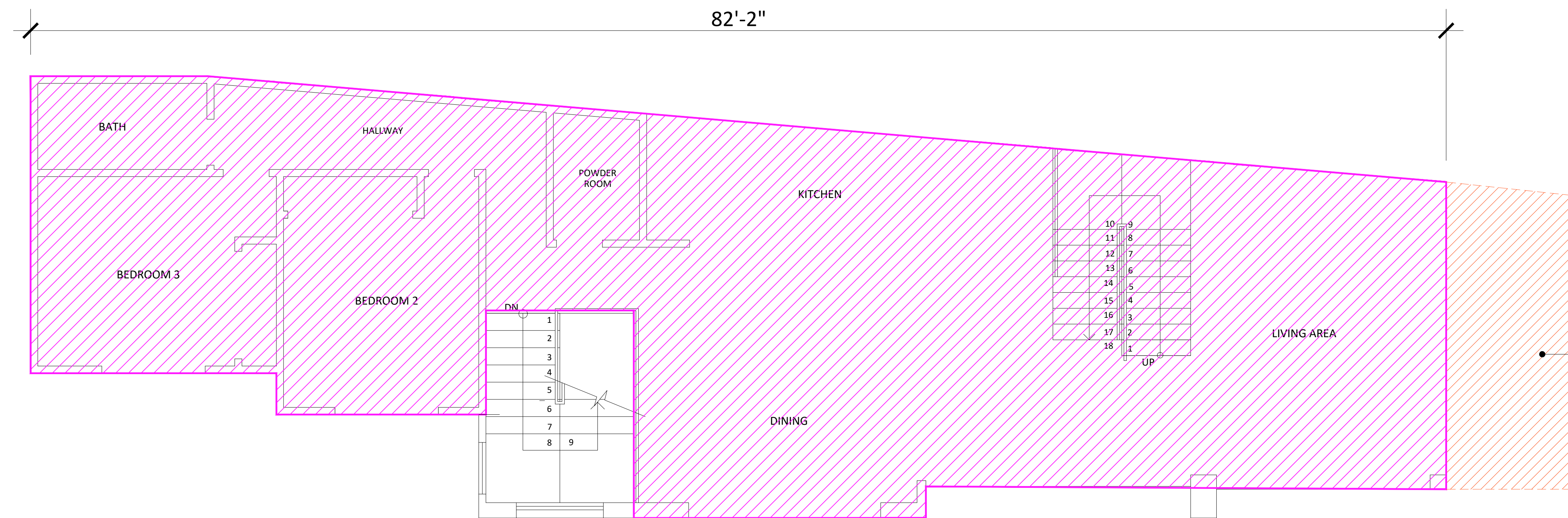

REVISED 1ST FLOOR PLAN = 1,537sq.ft.

3rd. SUBMITTAL 1st. FLOOR PLAN - 1,537 sq. ft.
CURRENT SUBMITTAL

AREA BEING REMOVED FROM 2ND SUBMITTAL

10.25.19

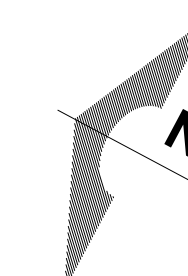

REVISION

MARK DATE REVISIONS



EC + Associates
e n g i n e e r i n g

8207 BROOKGREEN ROAD
DOWNEY, CA 90240
P: 562 708 3586 P: 562 714 2886

OWNER:
MR. EDUARDO J. CARRILLO

ADDRESS:
8207 BROOKGREEN RD.
DOWNEY, CA 90240

PROPOSED
NEW 2-STORY HOUSE

PROJECT ADDRESS:
1248 CORONA DR. GLENDALE, CA 91205
VACANT LAND,
GLENDALE CA 91205

CHECK AND VERIFY ALL DIMENSIONS BEFORE PROCEEDING WITH THE WORK. REPORT DISCREPANCIES TO THE ENGINEER. ALL CONSTRUCTION SHALL CONFORM TO THE C.B.C.

TITLE

FIRST FLOOR AREAS

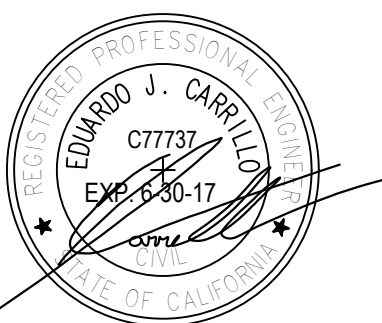

| | |
|-------------------------|------------------|
| JOB #: 15-000 | DRAWN: E.C. |
| DATE: 12 / 22 / 2016 | CHECKED: E.C. |

A-2.1a
SHEET OF

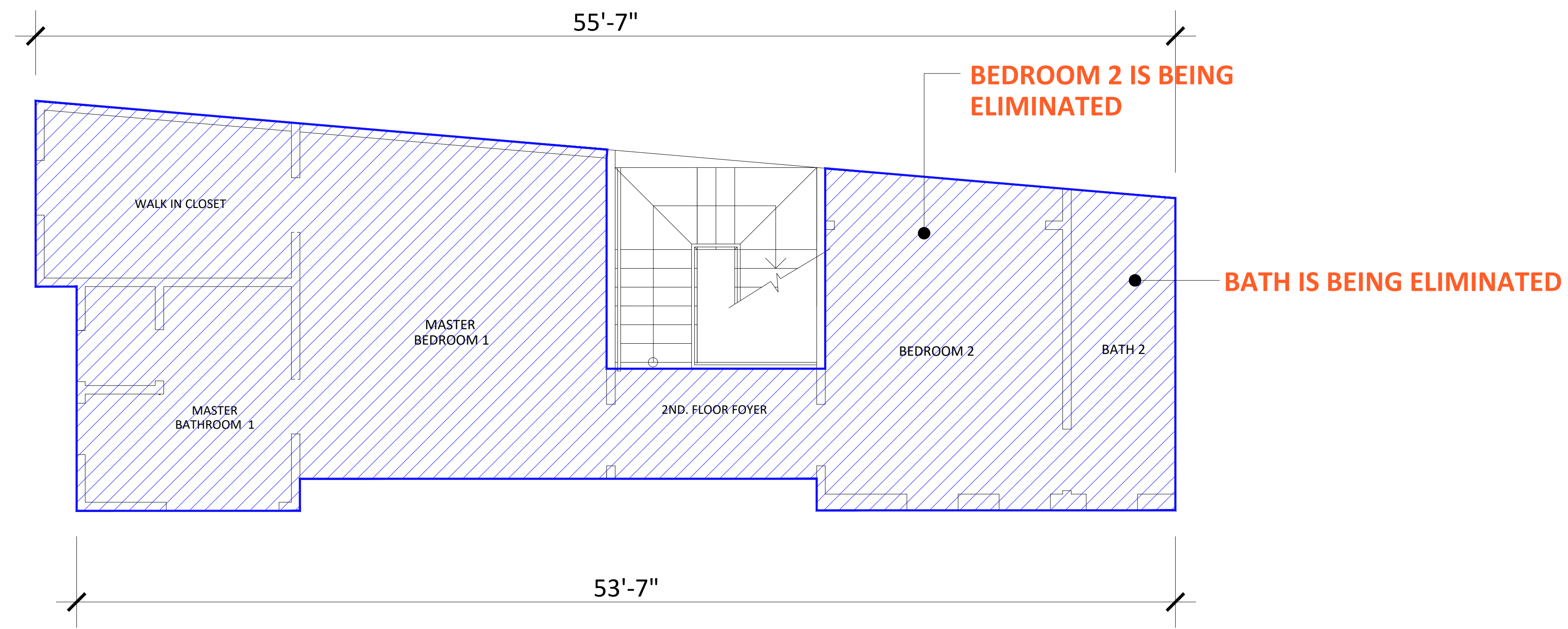

2ND SUBMITTAL 2ND FLOOR PLAN = 798 sq.ft.

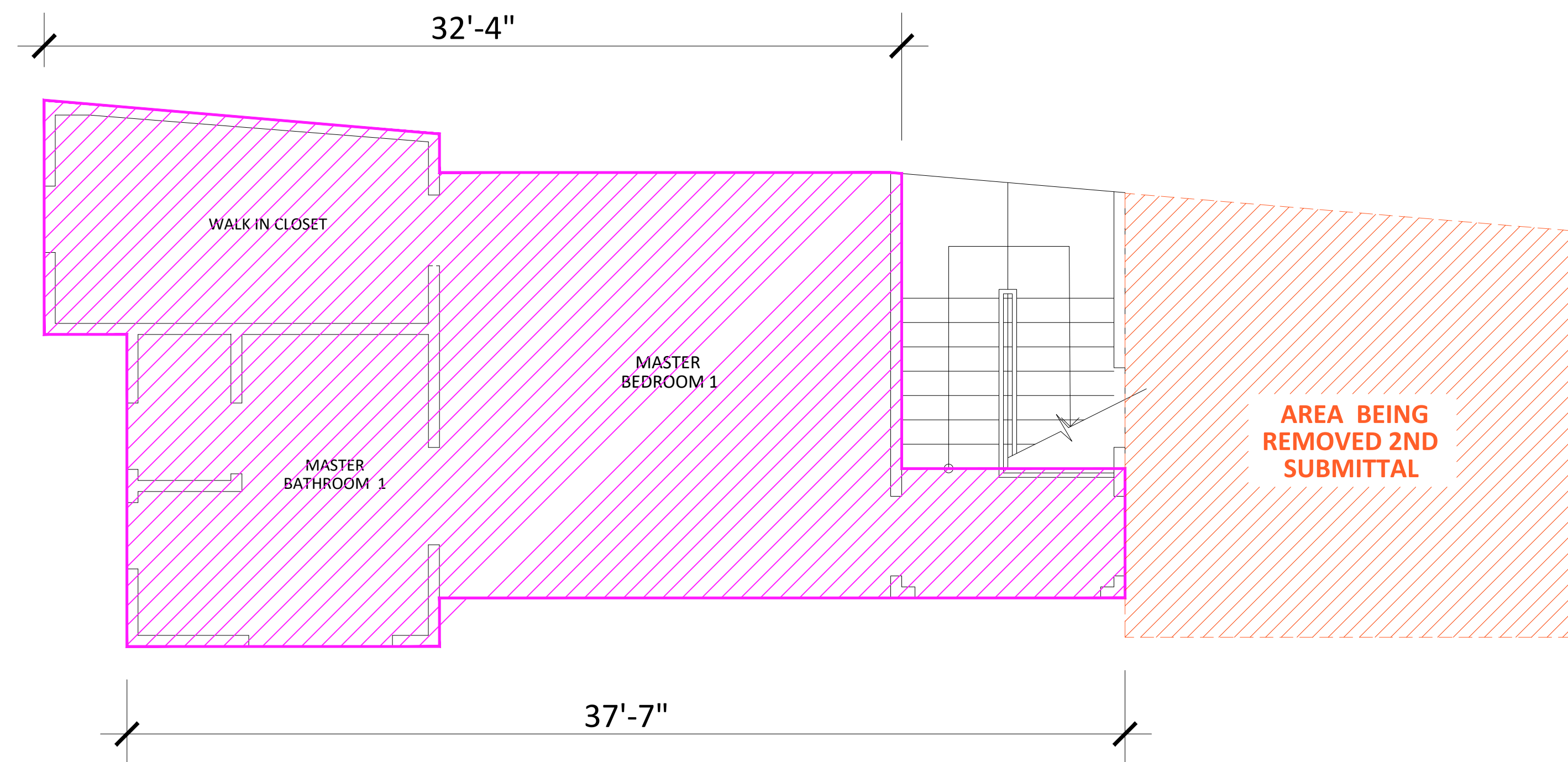

REVISED 2ND FLOOR PLAN = 580 sq.ft.
 3rd. SUBMITTAL 2nd. FLOOR PLAN - 580 sq. ft.
 CURRENT SUBMITTAL

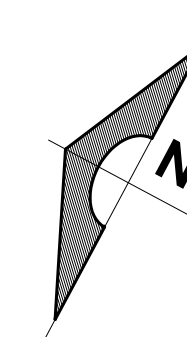

10.25.19

| REVISION | | |
|----------|------|-----------|
| MARK | DATE | REVISIONS |
| △ | | |
| △ | | |
| △ | | |

EC + Associates
 engineering
 8207 BROOKGREEN ROAD
 DOWNEY, CA 90240
 P: 562 708 3586 P: 562 714 2886

OWNER:
 MR. EDUARDO J. CARRILLO
 ADDRESS:
 8207 BROOKGREEN RD.
 DOWNEY, CA 90240

PROPOSED
 NEW 2-STORY HOUSE
 PROJECT ADDRESS:
 1246 CORONA DR. GLENDALE, CA 91205
 VACANT LAND,
 GLENDALE CA 91205

CHECK AND VERIFY ALL DIMENSIONS BEFORE PROCEEDING WITH THE WORK. REPORT DISCREPANCIES TO THE ENGINEER. ALL CONSTRUCTION SHALL CONFORM TO THE C.B.C.

TITLE

SECOND FLOOR AREAS

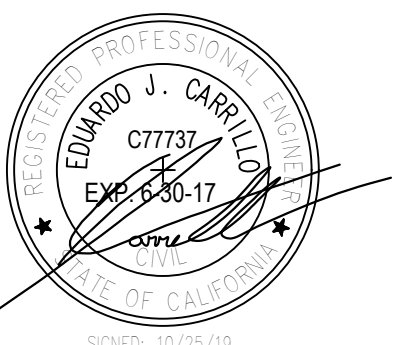

| | |
|-------------------------|------------------|
| JOB #: 15-000 | DRAWN: E.C. |
| DATE: 12 / 22 / 2016 | CHECKED: E.C. |

A-2.1b
 SHEET OF

| | |
|---|--|
| △ | |
| △ | |
| △ | |

EC + Associates
 engineering
 8207 BROOKGREEN ROAD
 DOWNEY, CA 90240
 P: 562 708 3586 P: 562 714 2886

OWNER:
 MR. EDUARDO J. CARRILLO
 ADDRESS:
 8207 BROOKGREEN RD.
 DOWNEY, CA 90240

PROPOSED
 NEW 2-STORY HOUSE
 PROJECT ADDRESS:
 1246 CORONA DR. GLENDALE, CA 91205
 VACANT LAND,
 GLENDALE CA 91205

CHECK AND VERIFY ALL
 DIMENSIONS BEFORE
 PROCEEDING WITH THE
 WORK. REPORT
 DISCREPANCIES TO THE
 ENGINEER. ALL
 CONSTRUCTION SHALL
 CONFORM TO THE C.B.C.

TITLE
**FIRST FLOOR
 PLAN**

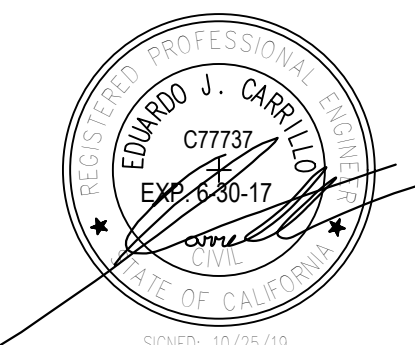

| | |
|----------------|----------|
| JOB #: | DRAWN: |
| 15-000 | E.C. |
| DATE: | CHECKED: |
| 12 / 22 / 2016 | E.C. |

A-2.1
 SHEET OF

| LEGEND | |
|--------|--|
| | CONCRETE WALLS (REFER TO STRUCTURAL PLANS FOR SPECIFICATIONS) |
| | NEW WALL CONSTRUCTION WITH 2x4 D.F.No2 AT 16"/O.C. AND 2x6 STUDS AT 16"/O.C. FOR PLUMBING WALLS |

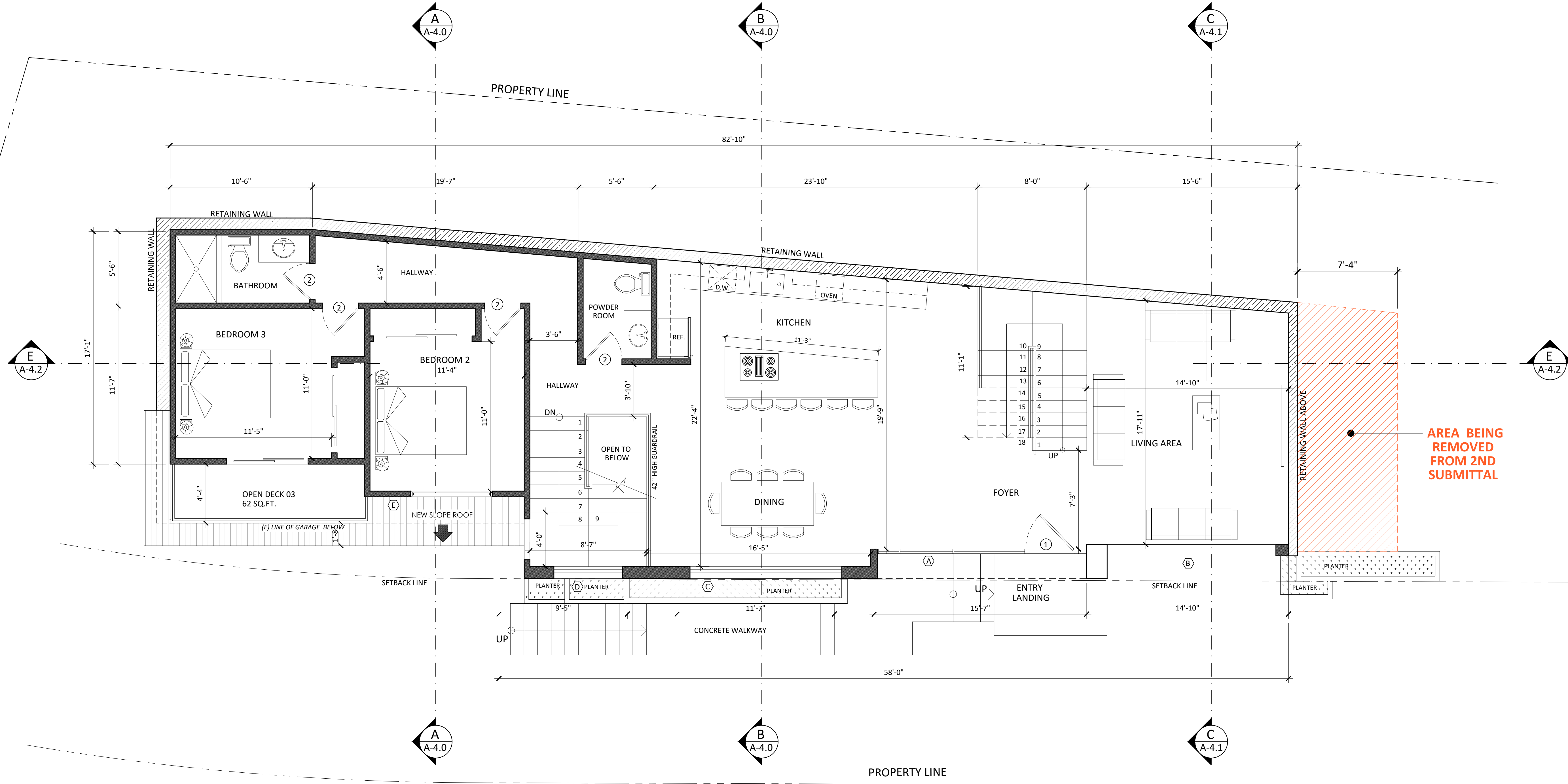

10.25.19

1 First floor plan (1,537 sq.ft.)
 SCALE 1/4" = 1'-0"
 OPEN DECK 03 = 62 sq.ft.

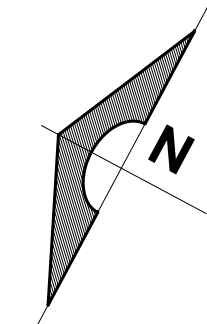

| | |
|---|--|
| △ | |
| △ | |
| △ | |

EC + Associates
engineering
 8207 BROOKGREEN ROAD
 DOWNEY, CA 90240
 P: 562 708 3586 P: 562 714 2886

OWNER:
 MR. EDUARDO J. CARRILLO
 ADDRESS:
 8207 BROOKGREEN RD.
 DOWNEY, CA 90240

PROPOSED
 NEW 2-STORY HOUSE
 PROJECT ADDRESS:
 1248 CORONA DR. GLENDALE, CA 91205
 VACANT LAND,
 GLENDALE CA 91205

CHECK AND VERIFY ALL
 DIMENSIONS BEFORE
 PROCEEDING WITH THE
 WORK. REPORT
 DISCREPANCIES TO THE
 ENGINEER. ALL
 CONSTRUCTION SHALL
 CONFORM TO THE C.B.C.

TITLE
**SECOND FLOOR
 PLAN**

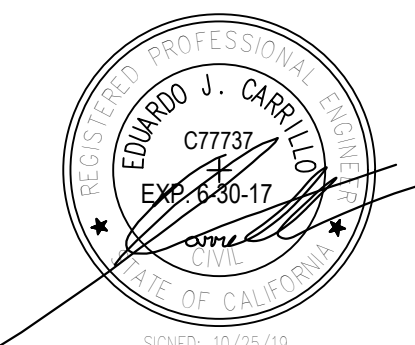

| | |
|----------------|----------|
| JOB #: | DRAWN: |
| 15-000 | E.C. |
| DATE: | CHECKED: |
| 12 / 22 / 2016 | E.C. |

A-2.2
 SHEET OF

| LEGEND | |
|--------|--|
| | CONCRETE WALLS (REFER TO STRUCTURAL PLANS FOR SPECIFICATIONS) |
| | NEW WALL CONSTRUCTION WITH 2x4 D.F.No2 AT 16"/O.C. AND 2x6 STUDS AT 16"/O.C. FOR PLUMBING WALLS |

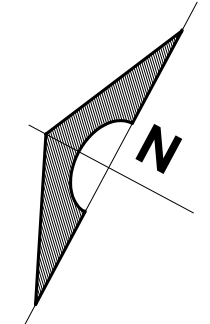
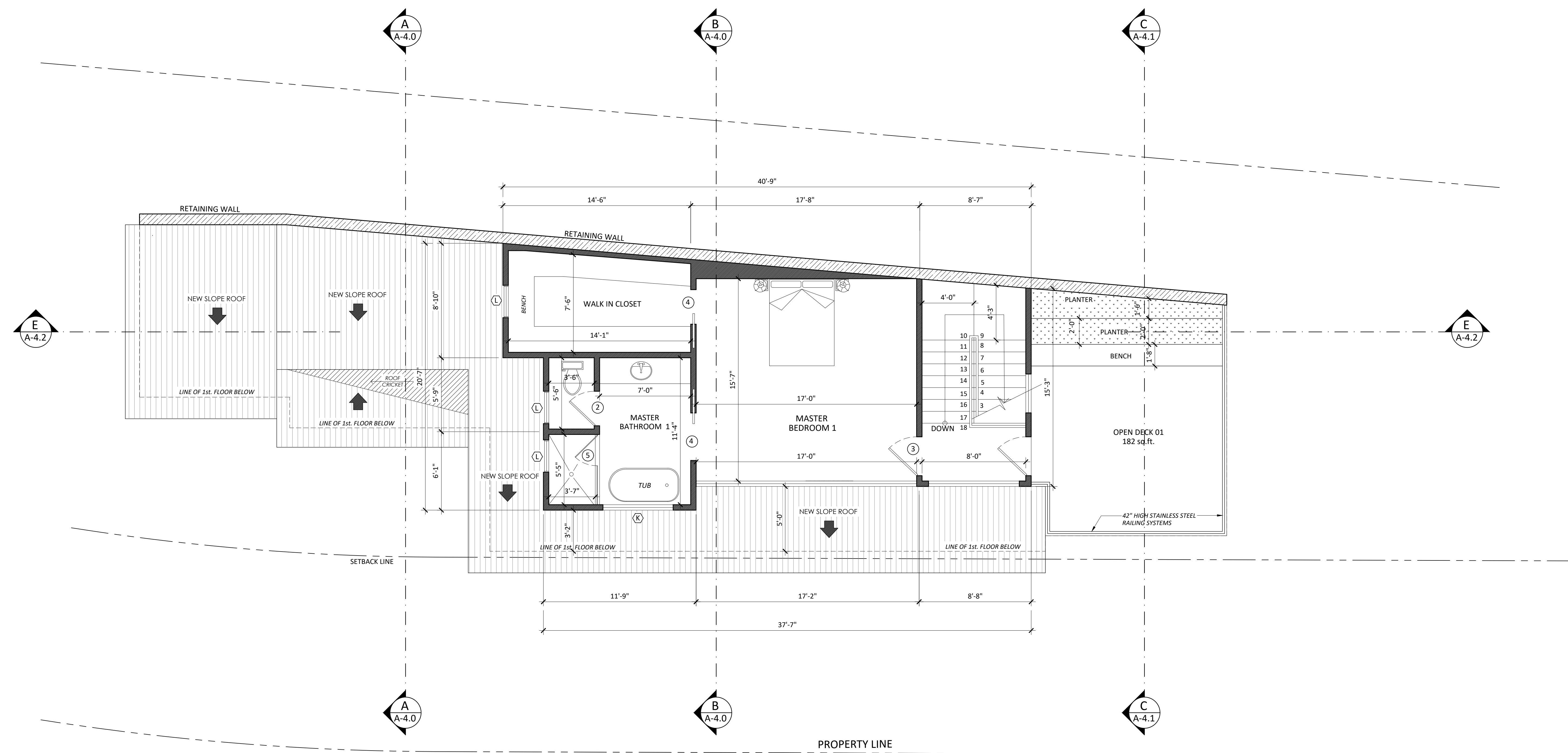

1 2nd floor plan (580 sq.ft.)
 SCALE 1/4" = 1'-0" OPEN DECK 01= 182 sq.ft.

10.25.19

REVISION

MARK DATE REVISIONS

| | | |
|--|--|--|
| | | |
| | | |
| | | |

EC + Associates
 e n g i n e e r i n g
 8207 BROOKGREEN ROAD
 DOWNEY, CA 90240
 P: 562 708 3586 F: 562 714 2886

OWNER:
 MR. EDUARDO J. CARRILLO
 ADDRESS:
 8207 BROOKGREEN RD.
 DOWNEY, CA 90240

PROJECT ADDRESS:
 1248 CORONA DR. GLENDALE, CA 91205
 VACANT LAND,
 GLENDALE CA 91205

CHECK AND VERIFY ALL DIMENSIONS BEFORE PROCEEDING WITH THE WORK. REPORT DISCREPANCIES TO THE ENGINEER. ALL CONSTRUCTION SHALL CONFORM TO THE C.B.C.

TITLE
ROOF PLAN

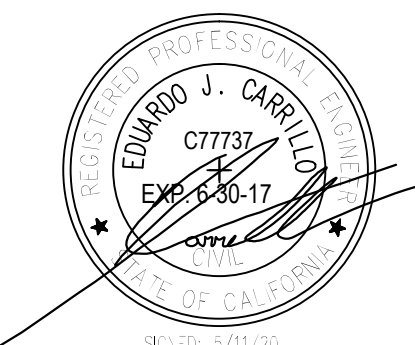

| | |
|-------------------------|------------------|
| JOB #: 15-000 | DRAWN: E.C. |
| DATE: 12 / 22 / 2015 | CHECKED: E.C. |

A-2.3
 SHEET OF

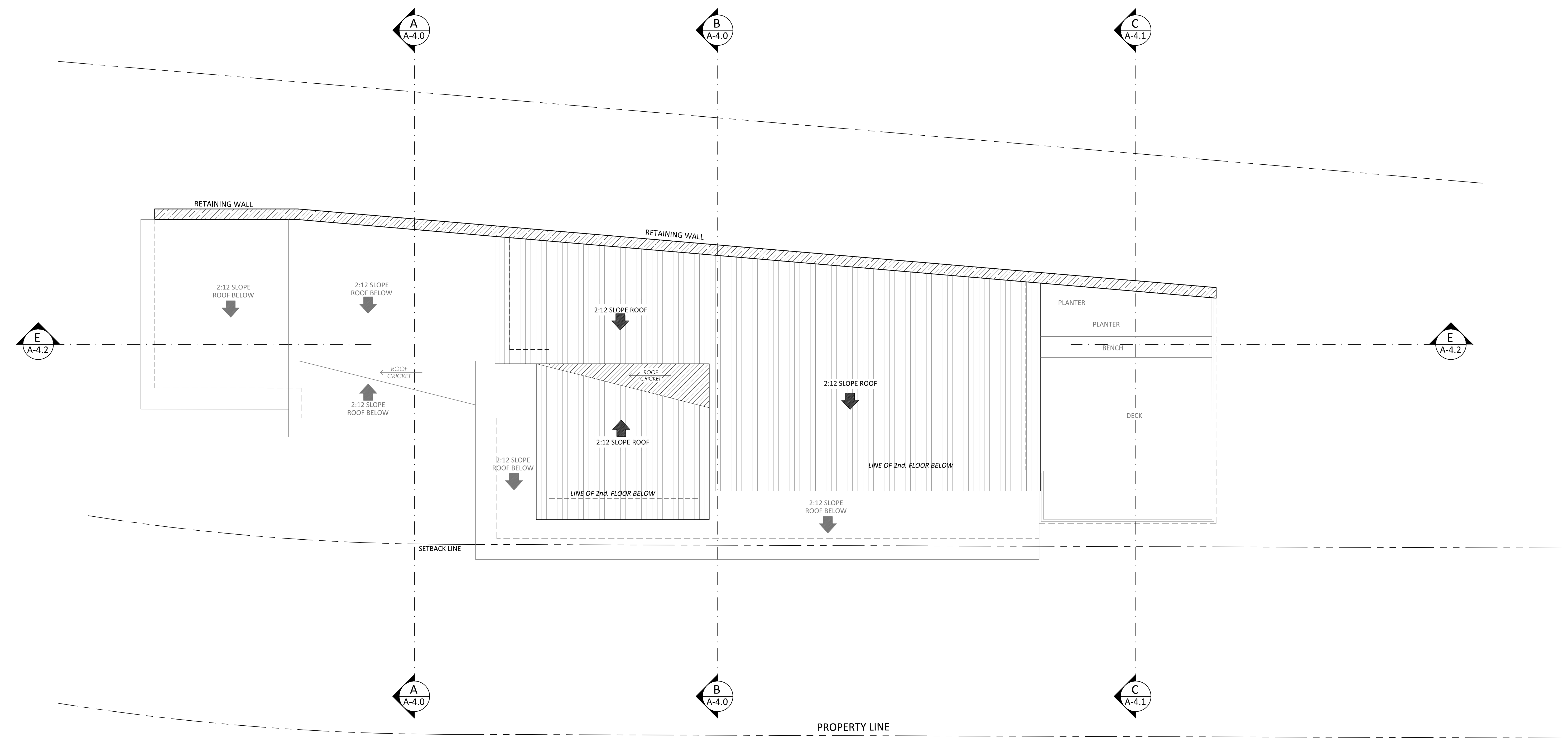

05.11.20

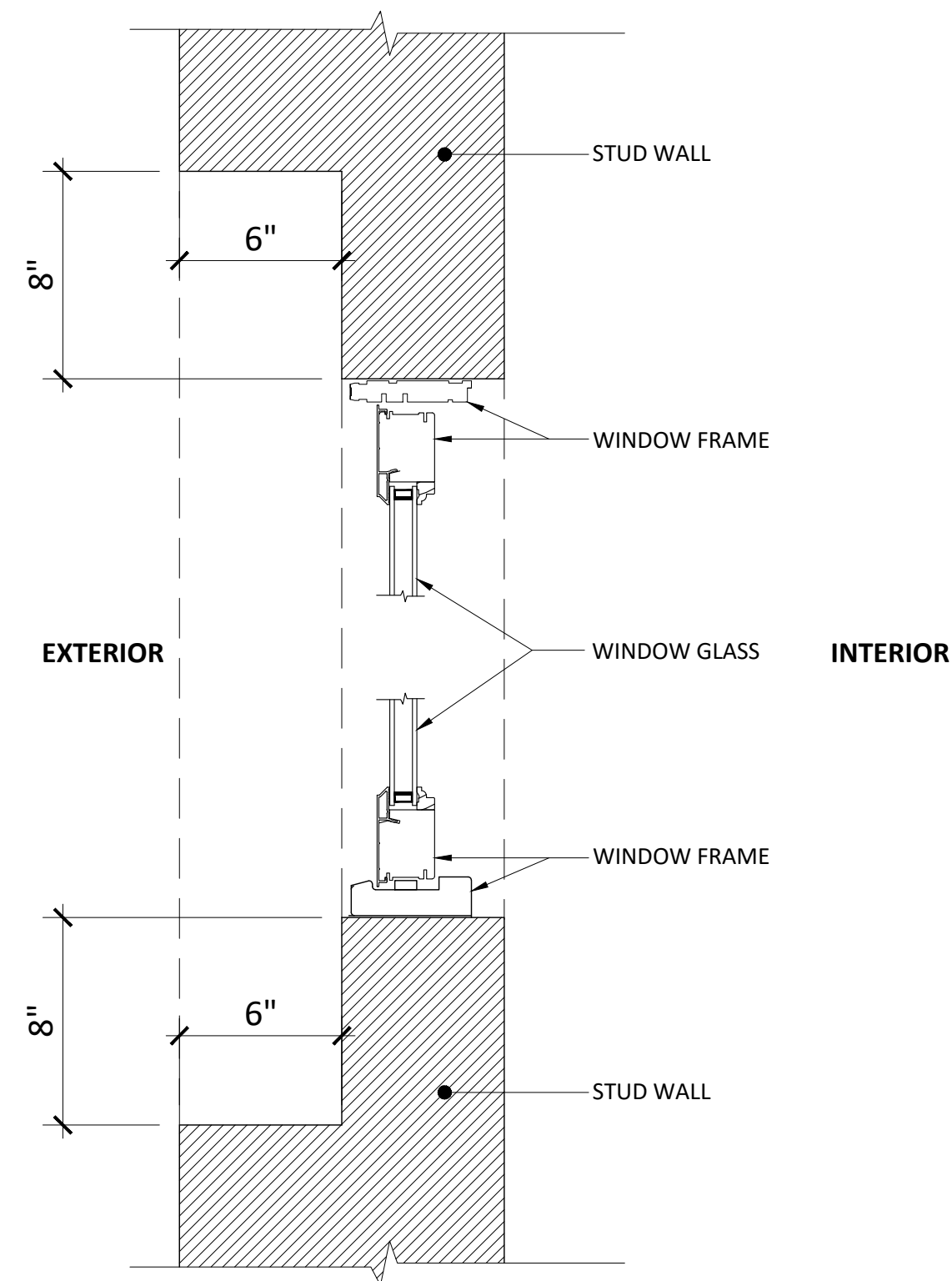

FLASH / RECESSED - WINDOW SECTION TYPE 3

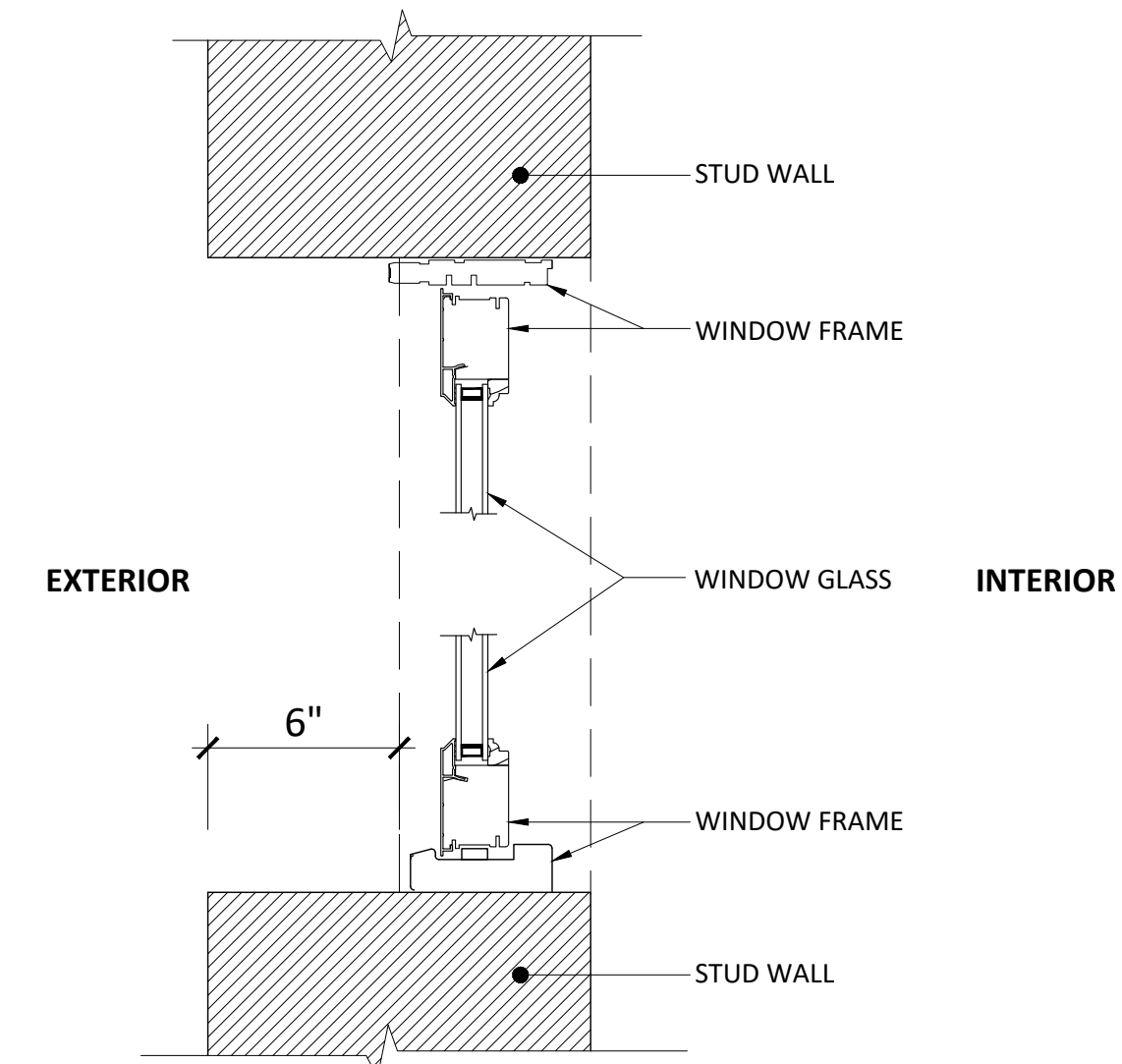

RECESSED - WINDOW SECTION TYPE 2

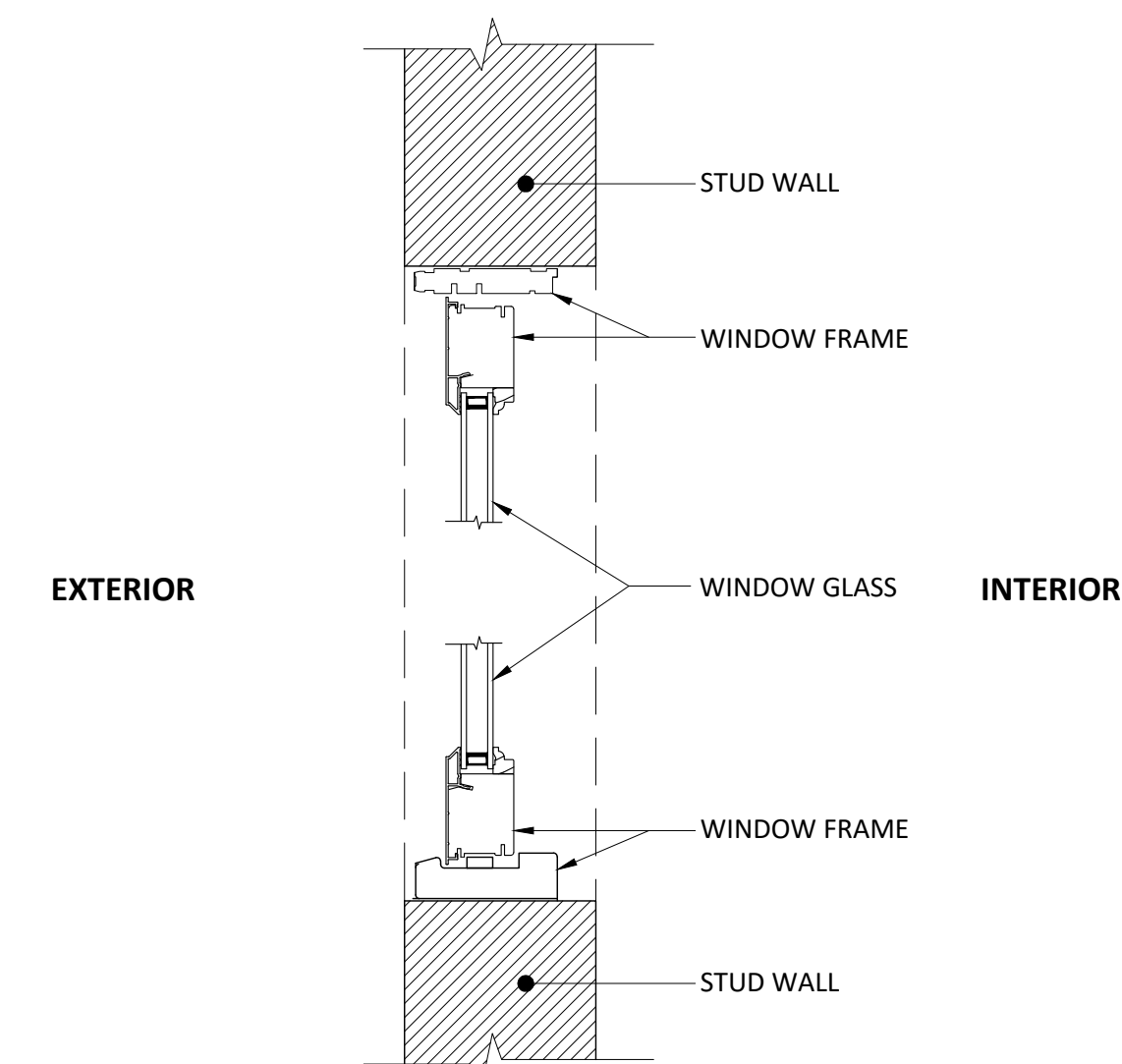

FLASH - WINDOW SECTION TYPE 1

DOOR TYPE / VIEW FROM EXTERIOR SIDE

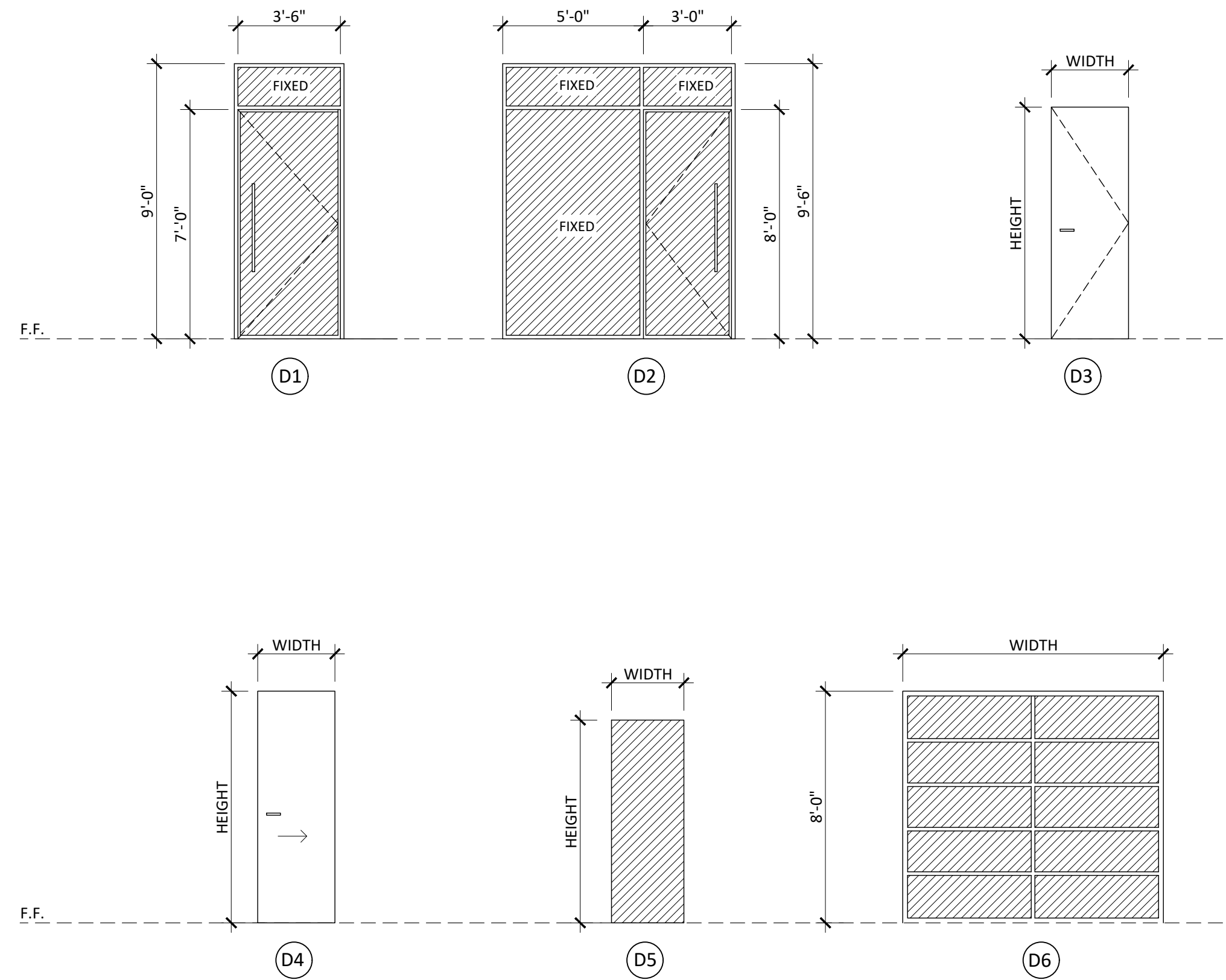

WINDOW TYPE / VIEW FROM EXTERIOR SIDE

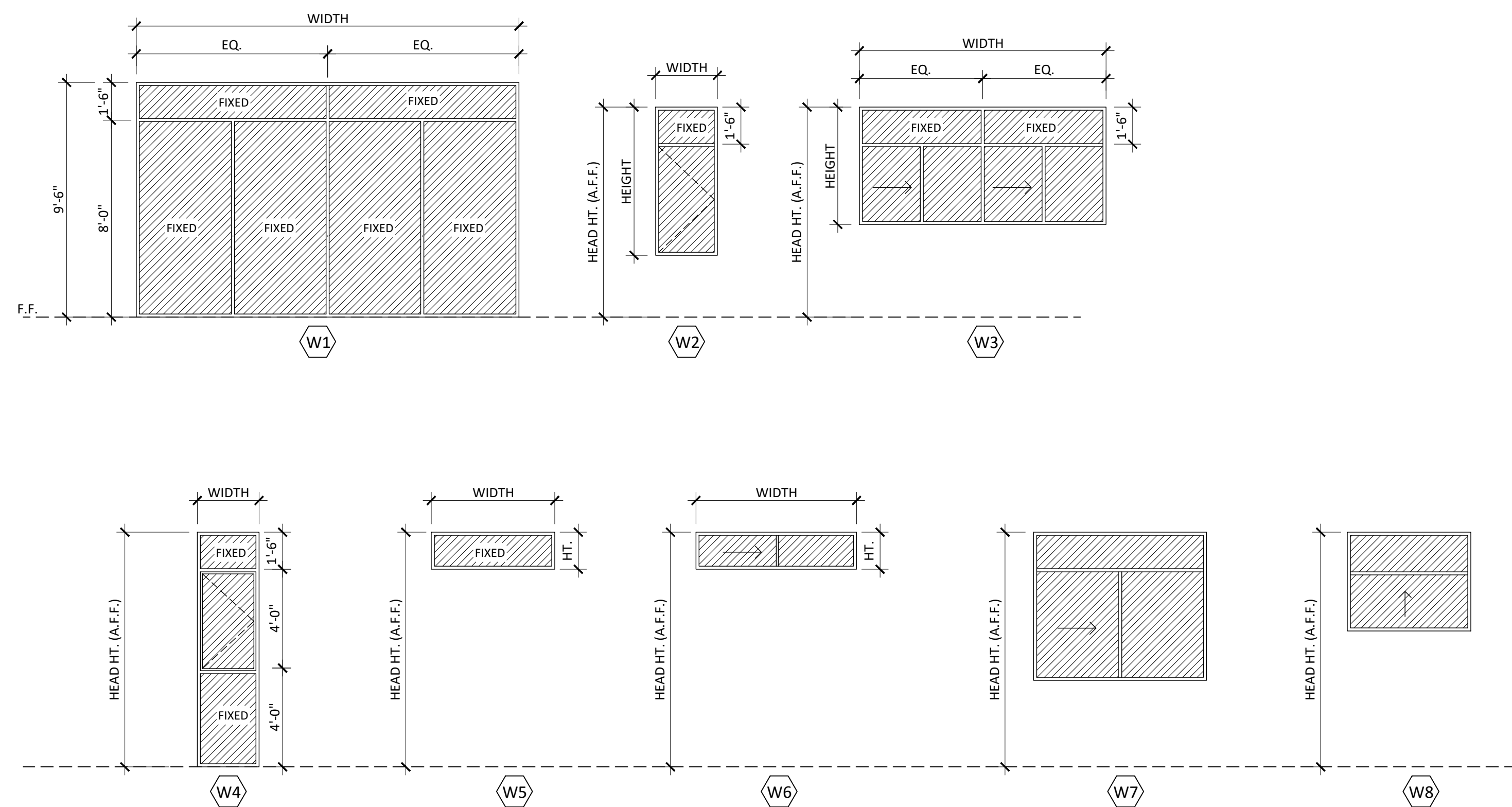

DOOR SCHEDULE

| SYM. | SIZE | | | TYPE | REMARKS | |
|------|-------|-------|--------|------|--------------------------------------|--|
| | W | H | THK. | | | |
| ① | 3'-6" | 7'-0" | 1-3/4" | D1 | ALUM. GLASS PANEL | SWING, TEMP. GLASS, FRONT DOOR |
| ② | 2'-8" | 8'-0" | 1-3/4" | D3 | WOOD SOLID CORE FLUSH SLAB | SWING DOOR, POWDER ROOM BEDROOM 2, 3 BATH 2 MASTER BATH |
| ③ | 3'-0" | 8'-0" | 1-3/4" | D3 | WOOD SOLID CORE FLUSH SLAB | BEDROOM 2, 3, MASTER BEDROOM 1 |
| ④ | 2'-8" | 8'-0" | 1-3/4" | D4 | WOOD SOLID CORE FLUSH SLAB | POCKET DOOR, MASTER BATH 1, WALK-IN CLOSET |
| ⑤ | 2'-6" | 7'-0" | --- | D5 | GLASS SHOWER DOOR | SLIDING, TEMPERED GLASS, DOOR & ENCLOSURE |
| ⑥ | 3'-0" | 8'-0" | 1-3/4" | D1 | ALUM. GLASS PANEL | SWING, TEMPERED GLASS, DECK 01 |
| ⑦ | 9'-9" | 8'-0" | --- | D6 | ALUM. GARAGE DOOR W/ GLASS PANELS | ROLL UP, GARAGE DOOR |
| ⑧ | 2'-8" | 8'-0" | 1-3/4" | D3 | WOOD SOLID CORE FLUSH SLAB | SWING, LAUNDRY ROOM |
| ⑨ | 3'-0" | 8'-0" | 1-3/4" | D3 | WOOD SOLID CORE FLUSH SLAB | SWING, GARGE |

WINDOW SCHEDULE

| SYM. | SIZE | | | HEAD HT. (A.F.F.) | TYPE | REMARKS | | | |
|------|--------|-------|--------|-------------------|------|-----------------------------|---|------------------|----------------------------|
| | W | H | THK. | | | | | | |
| A | 14'-0" | 8'-5" | 1-3/4" | 8'-6" | W1 | ALUM. CLAD, FIXED | 1 | FLUSH | TEMP. GLASS, ENTRY |
| B | 7'-0" | 6'-0" | 1-3/4" | 8'-6" | W7 | ALUM. CLAD, FIXED, SLIDER | 1 | FLUSH / RECESSED | LIVING ROOM |
| C | 10'-0" | 6'-0" | 1-3/4" | 8'-6" | W3 | ALUM. CLAD, FIXED, SLIDER | 1 | FLUSH / RECESSED | DINING |
| D | 5'-0" | 6'-0" | 1-3/4" | -- | W7 | ALUM. CLAD, FIXED, SLIDER | 1 | FLUSH / RECESSED | STAIRS |
| E | 5'-0" | 4'-0" | 1-3/4" | -- | W8 | ALUM. CLAD, SINGLE HUNG | 1 | FLUSH / RECESSED | STAIRS |
| F | 2'-0" | 9'-6" | 1-3/4" | 9'-6" | W1 | ALUM. CLAD, FIXED | 1 | FLUSH | BATHROOM 3 |
| G | 6'-0" | 1'-6" | 1-3/4" | 9'-6" | W6 | ALUM. CLAD, SLIDER | 1 | FLUSH | BATH 3 |
| H | 2'-6" | 9'-0" | 1-3/4" | 9'-0" | W1 | ALUM. CLAD, FIXED | 1 | FLUSH | MASTER BEDROOM 1 |
| I | 9'-6" | 9'-0" | 1-3/4" | 9'-0" | W1 | ALUM. CLAD, FIXED | 1 | FLUSH | MASTER BEDROOM 1 |
| J | 2'-6" | 6'-0" | 1-3/4" | 9'-0" | W2 | ALUM. CLAD, CASEMENT, FIXED | 1 | FLUSH / RECESSED | BEDROOM 2 |
| K | 5'-6" | 4'-0" | 1-3/4" | 9'-0" | W7 | ALUM. CLAD, CASEMENT, FIXED | 1 | FLUSH | MASTER BATH 1 |
| L | 2'-6" | 1'-6" | 1-3/4" | 9'-0" | W5 | ALUM. CLAD, AWNING | 3 | FLUSH | MASTERBATH, WALK-IN CLOSET |
| M | 3'-0" | 1'-6" | 1-3/4" | 8'-8" | W5 | ALUM. CLAD, SLIDER | 1 | FLUSH | BATH 2 |

NOTE:
ALL EXTERIOR DOORS FRAME AND ALL WINDOWS FRAME TO BE COLOR BLACK

REVISION

MARK DATE REVISIONS

| MARK | DATE | REVISIONS |
|------|------|-----------|
| △ | | |
| △ | | |
| △ | | |

EC + Associates
engineering

8207 BROOKGREEN ROAD
DOWNEY, CA 90240
P: 562 714 2886

OWNER:
MR. EDUARDO J. CARRILLO

ADDRESS:
8207 BROOKGREEN RD.
DOWNEY, CA 90240

PROPOSED
NEW 2-STORY HOUSE

PROJECT ADDRESS:
1248 CORONA DR. GLENDALE, CA 91205
VACANT LAND,
GLENDALE CA 91205

CHECK AND VERIFY ALL
DIMENSIONS BEFORE
PROCEEDING WITH THE
WORK. REPORT
DISCREPANCIES TO THE
ENGINEER. ALL
CONSTRUCTION SHALL
CONFORM TO THE C.B.C.

TITLE

**DOOR & WINDOW
SCHEDULE**



| | |
|-------------------------|------------------|
| JOB #: 15-000 | DRAWN: E.C. |
| DATE: 12 / 22 / 2016 | CHECKED: E.C. |

A-2.4
SHEET OF

REVISION

MARK DATE REVISIONS

| | | |
|---|--|--|
| △ | | |
| △ | | |
| △ | | |

EC + Associates
 engineering
 8207 BROOKGREEN ROAD
 DOWNEY, CA 90240
 P: 562 708 3586 P: 562 714 2886

OWNER:
 MR. EDUARDO J. CARRILLO
 ADDRESS:
 8207 BROOKGREEN RD.
 DOWNEY, CA 90240

PROPOSED
 NEW 2-STORY HOUSE
 PROJECT ADDRESS:
 1246 CORONA DR. GLENDALE, CA 91205
 VACANT LAND,
 GLENDALE CA 91205

CHECK AND VERIFY ALL
 DIMENSIONS BEFORE
 PROCEEDING WITH THE
 WORK. REPORT
 DISCREPANCIES TO THE
 ENGINEER. ALL
 CONSTRUCTION SHALL
 CONFORM TO THE C.B.C.

TITLE
**WEST EXTERIOR
 ELEVATION**

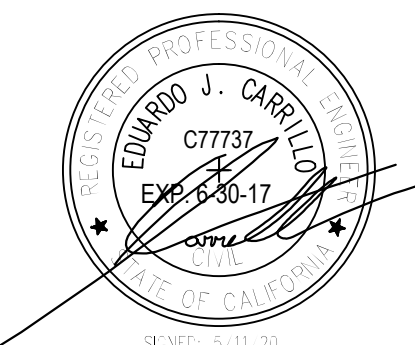

| | |
|-------------------------|------------------|
| JOB #: 15-000 | DRAWN: E.C. |
| DATE: 12 / 22 / 2016 | CHECKED: E.C. |

A-3.1a
 SHEET OF

PROPOSED FINISH KEYNOTES

- 1 7/8" EXTERIOR SMOOTH CEMENT STUCCO FINISH
MANUFACTURE: A HABRA COLOR LIGHT GREY
- 2 7/8" EXTERIOR SMOOTH CEMENT STUCCO FINISH
MANUFACTURE: A HABRA COLOR LIGHT BROWN
- 3 DOORS AND WINDOWS THERMALLY IMPROVED ALUMINUM
MANUFACTURER: MILGARD
FRAME COLOR: BLACK
STYLE: CONTEMPORARY
- 4 METAL DOWNSPOUT
COLOR: DARK GRAY
- 5 STAINLESS STEEL RAILING SYSTEMS
SQUARE POST WITH CABLE HOLDERS
MANUFACTURE: ATLANTIS RAILING SYSTEM
MODEL: SunRail™ Nautilus

- 7 CONCRETE WALLS
MATERIAL: TEXTURED POURED CONCRETE
FINISH: ROUGH
- 8 ALUMINUM GARAGE DOOR,
AVANTE™ COLLECTION
MANUFACTURE: CLOPAY
FRAME COLOR: BLACK (ANODIZED)
GLASS COLOR: WHITE ACRYLIC
- 9 WOOD STRIP SIDING PANELS
MANUFACTURE: ADVANTAGE-LUMBER
PRODUCT: IPE RAINSCREEN SIDING
- 10 CONCRETE SLAB & STEPS
MATERIAL: TEXTURED POURED CONCRETE
FINISH: ROUGH
- 11 METAL ROOF
MATERIAL: CONCEALED FASTENER METAL PANEL
FINISH: SILICONIZED POLYESTER

PROPOSED COLORS

- A DARK GRAY (TUXEDO 3033L)
BY: LA HABRA
FINISH: SANTA BARBARA
- B GRAY (BASALT 3015L)
BY: LA HABRA
FINISH: SANTA BARBARA
- C LIGHT GRAY (PLATEAU 3019L)
BY: LA HABRA
FINISH: SANTA BARBARA

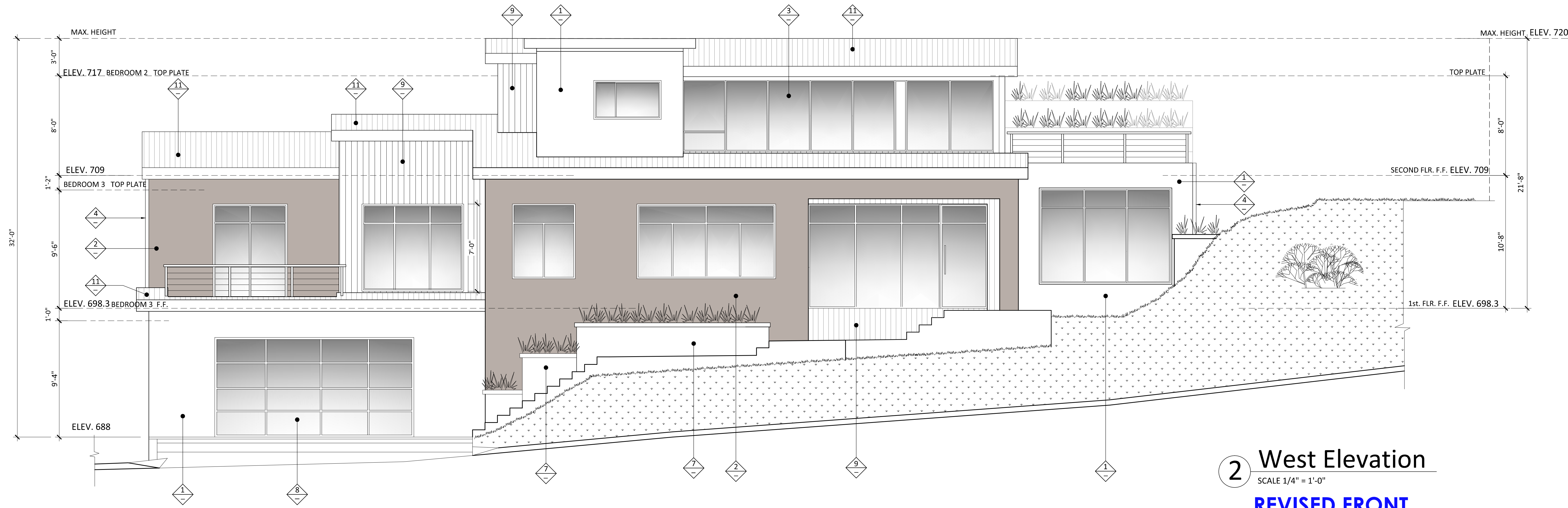

2 West Elevation
 SCALE 1/4" = 1'-0"
**REVISED FRONT
 ELEVATION**

05.11.20

| | | |
|---|--|--|
| △ | | |
| △ | | |
| △ | | |

EC + Associates
 engineering
 8207 BROOKGREEN ROAD
 DOWNEY, CA 90240
 P: 562 714 2886

OWNER:
 MR. EDUARDO J. CARRILLO
 ADDRESS:
 8207 BROOKGREEN RD.
 DOWNEY, CA 90240

PROPOSED
 NEW 2-STORY HOUSE
 PROJECT ADDRESS:
 1246 CORONA DR. GLENDALE, CA 91205
 VACANT LAND,
 GLENDALE CA 91205

CHECK AND VERIFY ALL
 DIMENSIONS BEFORE
 PROCEEDING WITH THE
 WORK. REPORT
 DISCREPANCIES TO THE
 ENGINEER. ALL
 CONSTRUCTION SHALL
 CONFORM TO THE C.B.C.

TITLE
**WEST EXTERIOR
 ELEVATION**

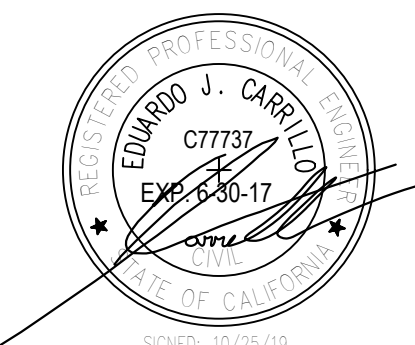

| | |
|-------------------------|------------------|
| JOB #: 15-000 | DRAWN: E.C. |
| DATE: 12 / 22 / 2016 | CHECKED: E.C. |

A-3.1b
 SHEET OF

PROPOSED FINISH KEYNOTES

- 1 7/8" EXTERIOR SMOOTH CEMENT STUCCO FINISH MANUFACTURE: A HABRA
- 2 SHOP FORM PRE-FINISHED METAL COPING CAP, COLOR TO MATCH WALL
- 3 DOORS AND WINDOWS THERMALLY IMPROVED ALUMINUM MANUFACTURER: MILGARD FRAME COLOR: BLACK STYLE: CONTEMPORARY
- 4 METAL DOWNSPOUT COLOR: DARK GRAY
- 5 STAINLESS STEEL RAILING SYSTEMS SQUARE POST WITH CABLE HOLDERS MANUFACTURE: ATLANTIS RAILING SYSTEM MODEL: SunRail™ Nautilus

PROPOSED COLORS

- 7 CONCRETE WALLS COLOR: LIGHT BROWN FINISH: ROUGH
- 8 ALUMINUM GARAGE DOOR, AVANTE™ COLLECTION MANUFACTURE: CLOPAY FRAME COLOR: BLACK (ANODIZED) GLASS COLOR: WHITE ACRYLIC
- 9 COMPOSITE ALUMINUM PANEL CLADDING SYSTEM MANUFACTURE: AL13 COLOR: ELEPHANT GREY
- 10 WOOD STRIP SIDING PANELS MANUFACTURE: ADVANTAGE-LUMBER PRODUCT: IPE RAINSCREEN SIDING
- 11 CONCRETE SLAB & STEPS COLOR: NATURAL COLOR FINISH: ROUGH
- A DARK GRAY (TUXEDO 3033L) BY: LA HABRA FINISH: SANTA BARBARA
- B GRAY (BASALT 3015L) BY: LA HABRA FINISH: SANTA BARBARA
- C LIGHT GRAY (PLATEAU 3019L) BY: LA HABRA FINISH: SANTA BARBARA

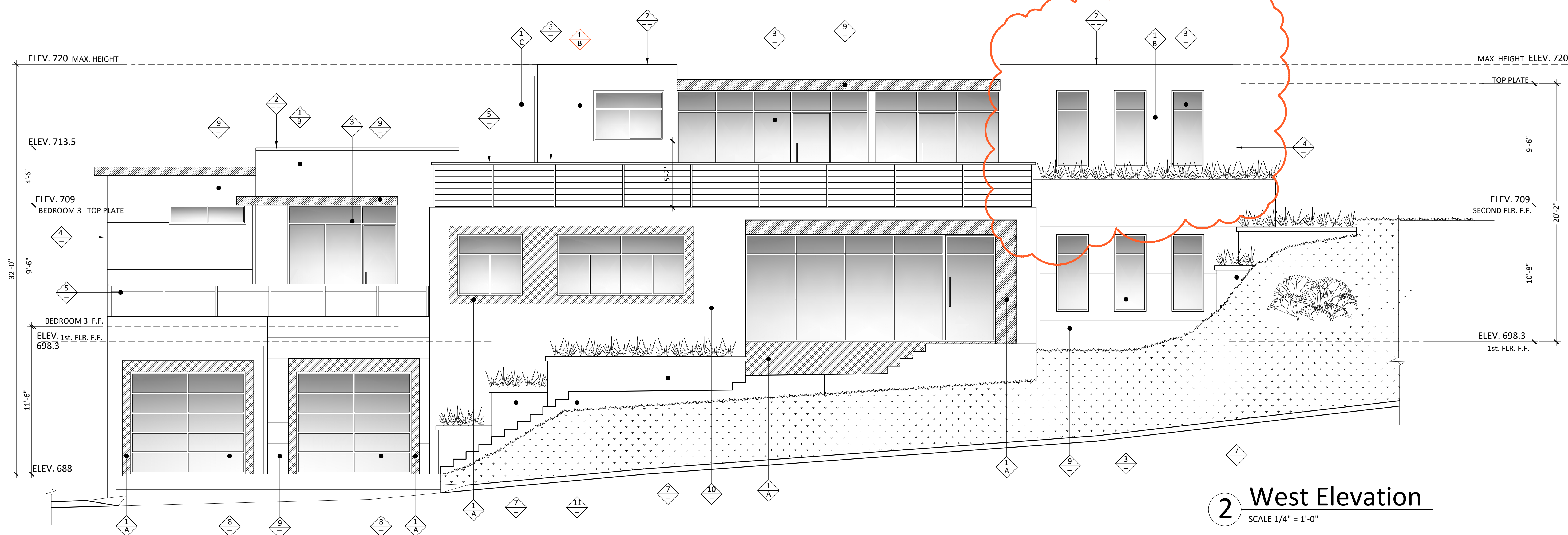

2 West Elevation
 SCALE 1/4" = 1'-0"

**ORIGINAL FRONT ELEVATION
 FROM 2ND SUBMITTAL
 FOR REFERENCE ONLY**

10.25.19

| | | |
|--|--|--|
| | | |
| | | |
| | | |

EC + Associates
 engineering
 8207 BROOKGREEN ROAD
 DOWNEY, CA 90240
 P: 562 708 3586 P: 562 714 2886

OWNER:
 MR. EDUARDO J. CARRILLO
 ADDRESS:
 8207 BROOKGREEN RD.
 DOWNEY, CA 90240

PROPOSED
 NEW 2-STORY HOUSE
 PROJECT ADDRESS:
 1246 CORONA DR. GLENDALE, CA 91205
 VACANT LAND,
 GLENDALE CA 91205

CHECK AND VERIFY ALL DIMENSIONS BEFORE PROCEEDING WITH THE WORK. REPORT DISCREPANCIES TO THE ENGINEER. ALL CONSTRUCTION SHALL CONFORM TO THE C.B.C.

TITLE
NORTH & SOUTH EXTERIOR ELEVATION

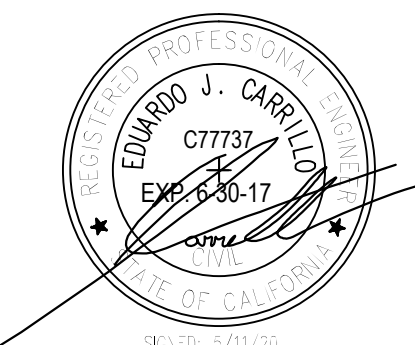

| | |
|-------------------------|------------------|
| JOB #: 15-000 | DRAWN: E.C. |
| DATE: 12 / 22 / 2016 | CHECKED: E.C. |

A-3.2
 SHEET OF

PROPOSED FINISH KEYNOTES

- 1 7/8" EXTERIOR SMOOTH CEMENT STUCCO FINISH
MANUFACTURE: A HABRA COLOR LIGHT GREY
- 2 7/8" EXTERIOR SMOOTH CEMENT STUCCO FINISH
MANUFACTURE: A HABRA COLOR LIGHT BROWN
- 3 DOORS AND WINDOWS THERMALLY IMPROVED ALUMINUM
MANUFACTURER: MILGARD
FRAME COLOR: BLACK
STYLE: CONTEMPORARY
- 4 METAL DOWNSPOUT
COLOR: DARK GRAY
- 5 STAINLESS STEEL RAILING SYSTEMS
SQUARE POST WITH CABLE HOLDERS
MANUFACTURE: ATLANTIS RAILING SYSTEM
MODEL: SunRail™ Nautilus

PROPOSED COLORS

- 7 CONCRETE WALLS
MATERIAL: TEXTURED POURED CONCRETE
FINISH: ROUGH
- 8 ALUMINUM GARAGE DOOR, AVANTE™ COLLECTION
MANUFACTURE: CLOPAY
FRAME COLOR: BLACK (ANODIZED)
GLASS COLOR: WHITE ACRYLIC
- 9 WOOD STRIP SIDING PANELS
MANUFACTURE: ADVANTAGE-LUMBER
PRODUCT: IPE RAINSCREEN SIDING
- 10 CONCRETE SLAB & STEPS
MATERIAL: TEXTURED POURED CONCRETE
FINISH: ROUGH
- 11 METAL ROOF
MATERIAL: CONCEALED FASTENER METAL PANEL
FINISH: SILICONIZED POLYESTER

- A **DARK GRAY** (TUXEDO 3033L)
BY: LA HABRA
FINISH: SANTA BARBARA
- B **GRAY** (BASALT 3015L)
BY: LA HABRA
FINISH: SANTA BARBARA
- C **LIGHT GRAY** (PLATEAU 3019L)
BY: LA HABRA
FINISH: SANTA BARBARA

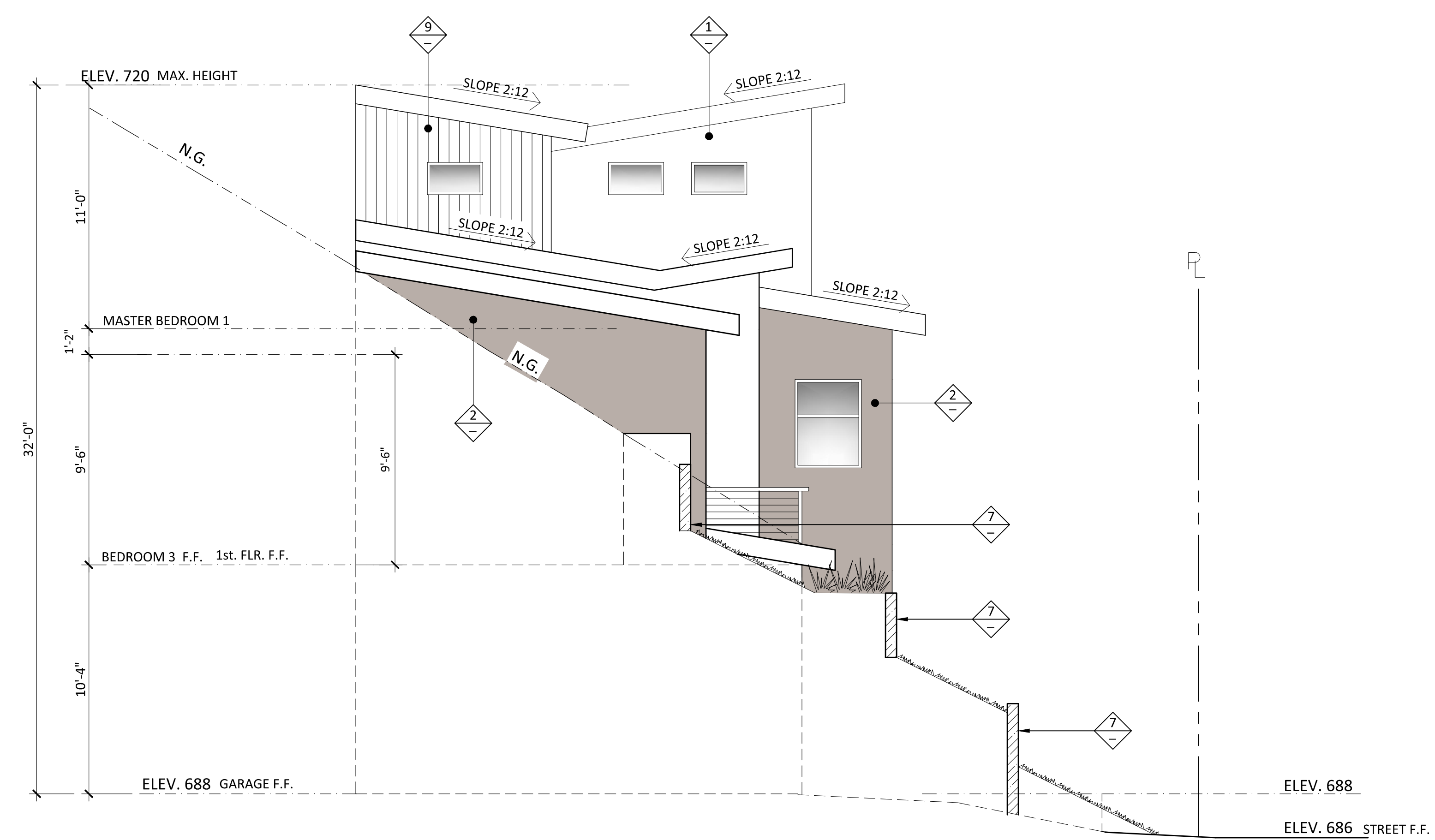

2 North Elevation
 SCALE 1/4" = 1'-0"

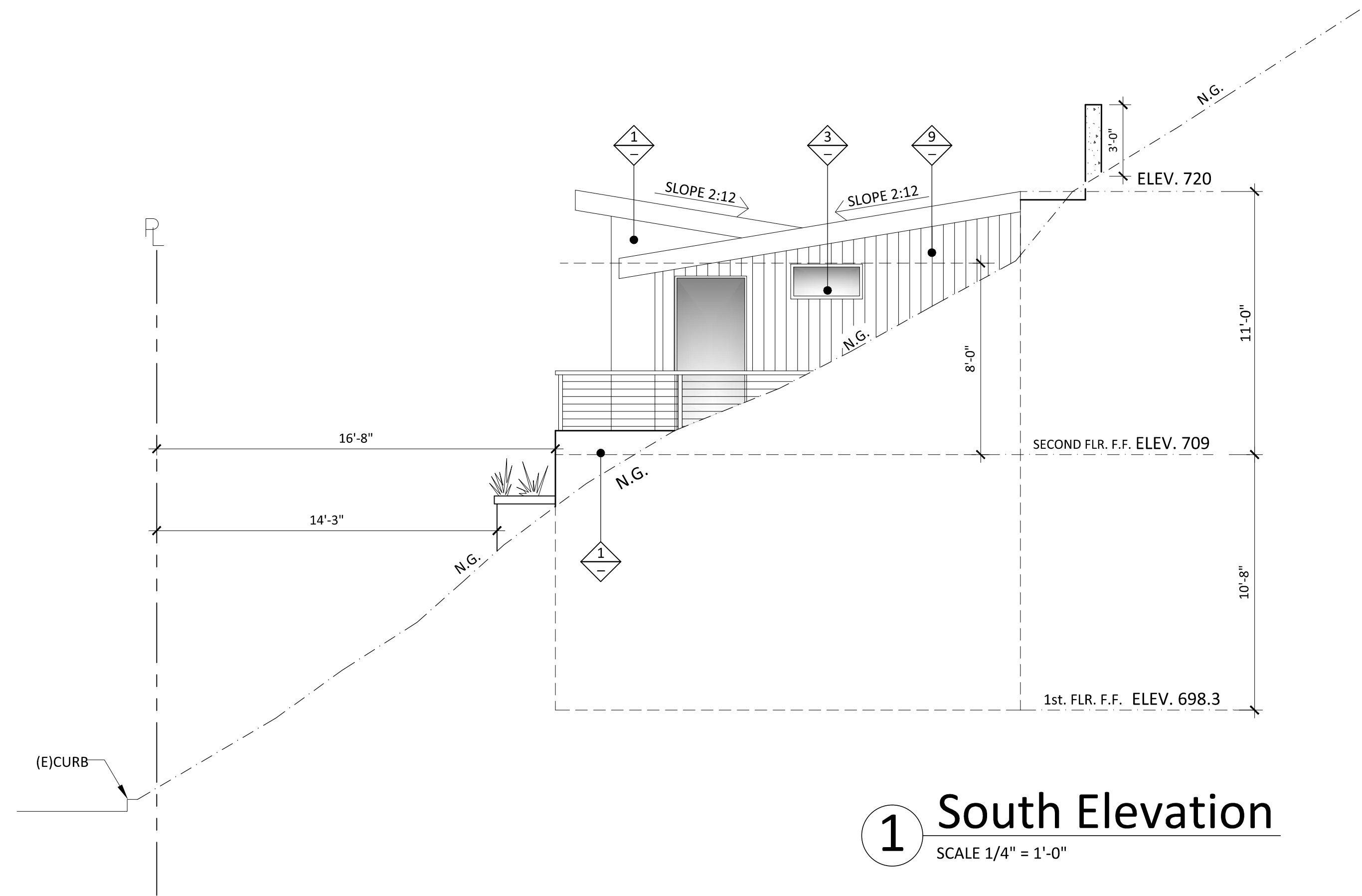

1 South Elevation
 SCALE 1/4" = 1'-0"

05.11.20

REVISION

MARK DATE REVISIONS

| | | |
|---|--|--|
| △ | | |
| △ | | |
| △ | | |

EC + Associates
 engineering
 8207 BROOKGREEN ROAD
 DOWNEY, CA 90240
 P: 562 708 3586 P: 562 714 2886

OWNER:
 MR. EDUARDO J. CARRILLO
 ADDRESS:
 8207 BROOKGREEN RD.
 DOWNEY, CA 90240

PROPOSED
 NEW 2-STORY HOUSE
 PROJECT ADDRESS:
 1248 CORONA DR. GLENDALE, CA 91205
 VACANT LAND,
 GLENDALE CA 91205

CHECK AND VERIFY ALL DIMENSIONS BEFORE PROCEEDING WITH THE WORK. REPORT DISCREPANCIES TO THE ENGINEER. ALL CONSTRUCTION SHALL CONFORM TO THE C.B.C.

TITLE
COLORED WEST ELEVATION

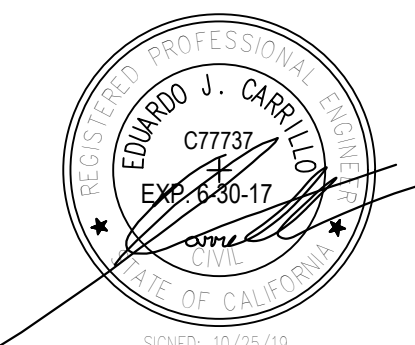

| | |
|-------------------------|------------------|
| JOB #: 15-000 | DRAWN: E.C. |
| DATE: 12 / 22 / 2016 | CHECKED: E.C. |

A-3.3
 SHEET OF

PROPOSED FINISH KEYNOTES

- 1 7/8" EXTERIOR SMOOTH CEMENT STUCCO FINISH
MANUFACTURE: A HABRA COLOR LIGHT GREY
- 2 7/8" EXTERIOR SMOOTH CEMENT STUCCO FINISH
MANUFACTURE: A HABRA COLOR LIGHT BROWN
- 3 DOORS AND WINDOWS
THERMALLY IMPROVED ALUMINUM
MANUFACTURER: MILGARD
FRAME COLOR: BLACK
STYLE: CONTEMPORARY
- 4 METAL DOWNSPOUT
COLOR: DARK GRAY
- 5 STAINLESS STEEL RAILING SYSTEMS
SQUARE POST WITH CABLE HOLDERS
MANUFACTURE: ATLANTIS RAILING SYSTEM
MODEL: SunRail™ Nautilus

- 7 CONCRETE WALLS
MATERIAL: TEXTURED Poured CONCRETE
FINISH: ROUGH
- 8 ALUMINUM GARAGE DOOR,
AVANTE™ COLLECTION
MANUFACTURE: CLOPAY
FRAME COLOR: BLACK (ANODIZED)
GLASS COLOR: WHITE ACRYLIC
- 9 WOOD STRIP SIDING PANELS
MANUFACTURE: ADVANTAGE-LUMBER
PRODUCT: IPE RAINSCREEN SIDING
- 10 CONCRETE SLAB & STEPS
MATERIAL: TEXTURED Poured CONCRETE
FINISH: ROUGH
- 11 METAL ROOF
MATERIAL: CONCEALED FASTENER METAL PANEL
FINISH: SILICONIZED POLYESTER

PROPOSED COLORS

- A **DARK GRAY** (TUXEDO 3033L)
BY: LA HABRA
FINISH: SANTA BARBARA
- B **GRAY** (BASALT 3015L)
BY: LA HABRA
FINISH: SANTA BARBARA
- C **LIGHT GRAY** (PLATEAU 3019L)
BY: LA HABRA
FINISH: SANTA BARBARA



2 West Elevation
 SCALE 1/4" = 1'-0"

10.25.19

REVISION

MARK DATE REVISIONS

| | | |
|---|--|--|
| △ | | |
| △ | | |
| △ | | |

EC + Associates
 engineering
 8207 BROOKGREEN ROAD
 DOWNEY, CA 90240
 P: 562 708 3586 P: 562 714 2886

OWNER:
 MR. EDUARDO J. CARRILLO
 ADDRESS:
 8207 BROOKGREEN RD.
 DOWNEY, CA 90240

PROPOSED
 NEW 2-STORY HOUSE
 PROJECT ADDRESS:
 1248 CORONA DR. GLENDALE, CA 91205
 VACANT LAND,
 GLENDALE CA 91205

CHECK AND VERIFY ALL DIMENSIONS BEFORE PROCEEDING WITH THE WORK. REPORT DISCREPANCIES TO THE ENGINEER. ALL CONSTRUCTION SHALL CONFORM TO THE C.B.C.

TITLE
COLORED SOUTH & NORTH ELEVATION

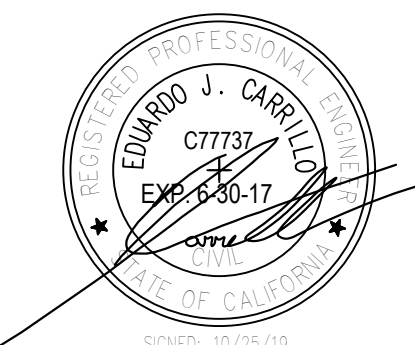

| | |
|-------------------------|------------------|
| JOB #: 15-000 | DRAWN: E.C. |
| DATE: 12 / 22 / 2016 | CHECKED: E.C. |

A-3.4
 SHEET OF

PROPOSED FINISH KEYNOTES

- 1 7/8" EXTERIOR SMOOTH CEMENT STUCCO FINISH
MANUFACTURE: A HABRA COLOR LIGHT GREY
- 2 7/8" EXTERIOR SMOOTH CEMENT STUCCO FINISH
MANUFACTURE: A HABRA COLOR LIGHT BROWN
- 3 DOORS AND WINDOWS THERMALLY IMPROVED ALUMINUM
MANUFACTURER: MILGARD
FRAME COLOR: BLACK
STYLE: CONTEMPORARY
- 4 METAL DOWNSPOUT
COLOR: DARK GRAY
- 5 STAINLESS STEEL RAILING SYSTEMS
SQUARE POST WITH CABLE HOLDERS
MANUFACTURE: ATLANTIS RAILING SYSTEM
MODEL: SunRail™ Nautilus

PROPOSED COLORS

- 7 CONCRETE WALLS
MATERIAL: TEXTURED POURED CONCRETE
FINISH: ROUGH
- 8 ALUMINUM GARAGE DOOR,
AVANTE™ COLLECTION
MANUFACTURE: CLOPAY
FRAME COLOR: BLACK (ANODIZED)
GLASS COLOR: WHITE ACRYLIC
- 9 WOOD STRIP SIDING PANELS
MANUFACTURE: ADVANTAGE-LUMBER
PRODUCT: IPE RAINSCREEN SIDING
- 10 CONCRETE SLAB & STEPS
MATERIAL: TEXTURED POURED CONCRETE
FINISH: ROUGH
- 11 METAL ROOF
MATERIAL: CONCEALED FASTENER METAL PANEL
FINISH: SILICONIZED POLYESTER

- A **DARK GRAY** (TUXEDO 3033L)
BY: LA HABRA
FINISH: SANTA BARBARA
- B **GRAY** (BASALT 3015L)
BY: LA HABRA
FINISH: SANTA BARBARA
- C **LIGHT GRAY** (PLATEAU 3019L)
BY: LA HABRA
FINISH: SANTA BARBARA

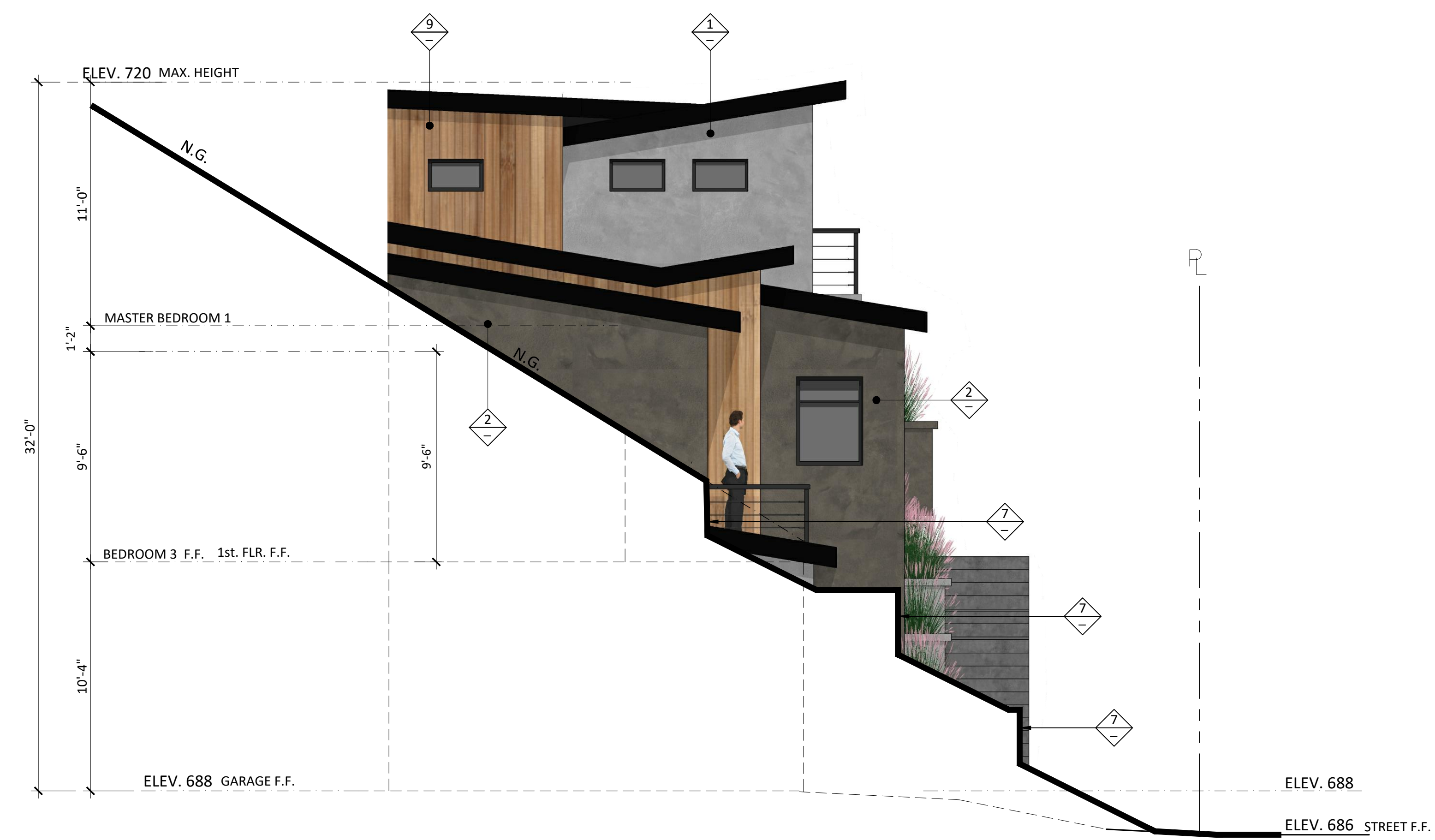

2 North Elevation
 SCALE 1/4" = 1'-0"

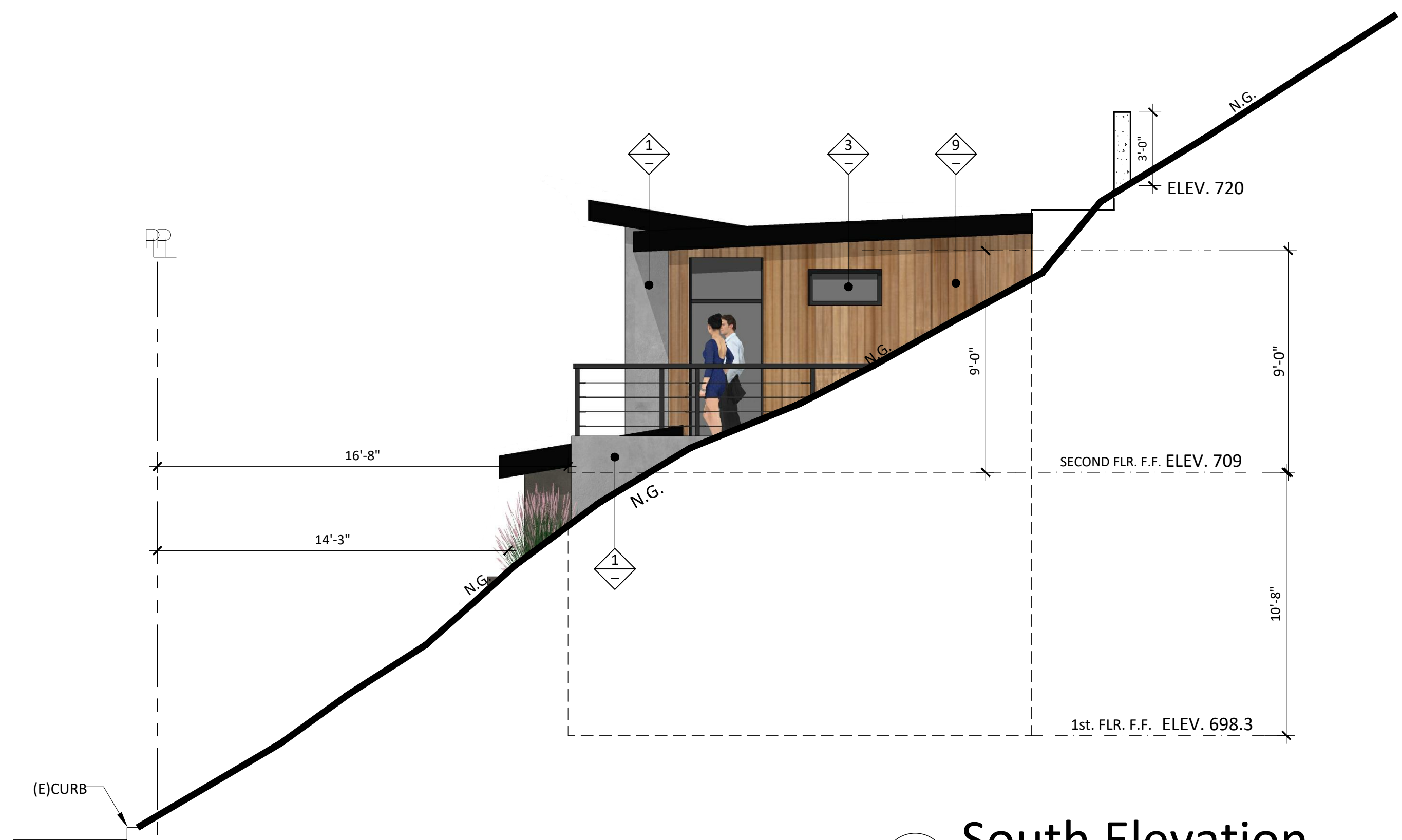

1 South Elevation
 SCALE 1/4" = 1'-0"

10 25 10

REVISION

MARK DATE REVISIONS

| | | |
|---|--|--|
| △ | | |
| △ | | |
| △ | | |

EC + Associates
 e n g i n e e r i n g
 8207 BROOKGREEN ROAD
 DOWNEY, CA 90240
 P: 562 708 3586 P: 562 714 2886

OWNER:
 MR. EDUARDO J. CARRILLO
 ADDRESS:
 8207 BROOKGREEN RD.
 DOWNEY, CA 90240

PROPOSED
 NEW 2-STORY HOUSE
 PROJECT ADDRESS:
 1246 CORONA DR. GLENDALE, CA 91205
 VACANT LAND,
 GLENDALE CA 91205

CHECK AND VERIFY ALL DIMENSIONS BEFORE PROCEEDING WITH THE WORK. REPORT DISCREPANCIES TO THE ENGINEER. ALL CONSTRUCTION SHALL CONFORM TO THE C.B.C.

TITLE
 SITE CROSS SECTION C

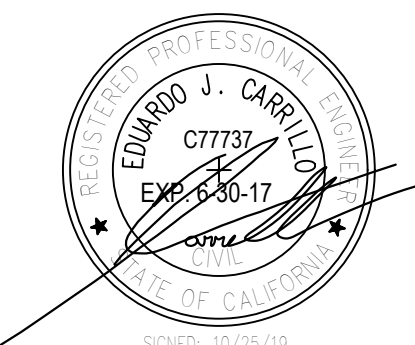

| | |
|-------------------------|------------------|
| JOB #: 15-000 | DRAWN: E.C. |
| DATE: 12 / 22 / 2016 | CHECKED: E.C. |

A-4.1
 SHEET OF

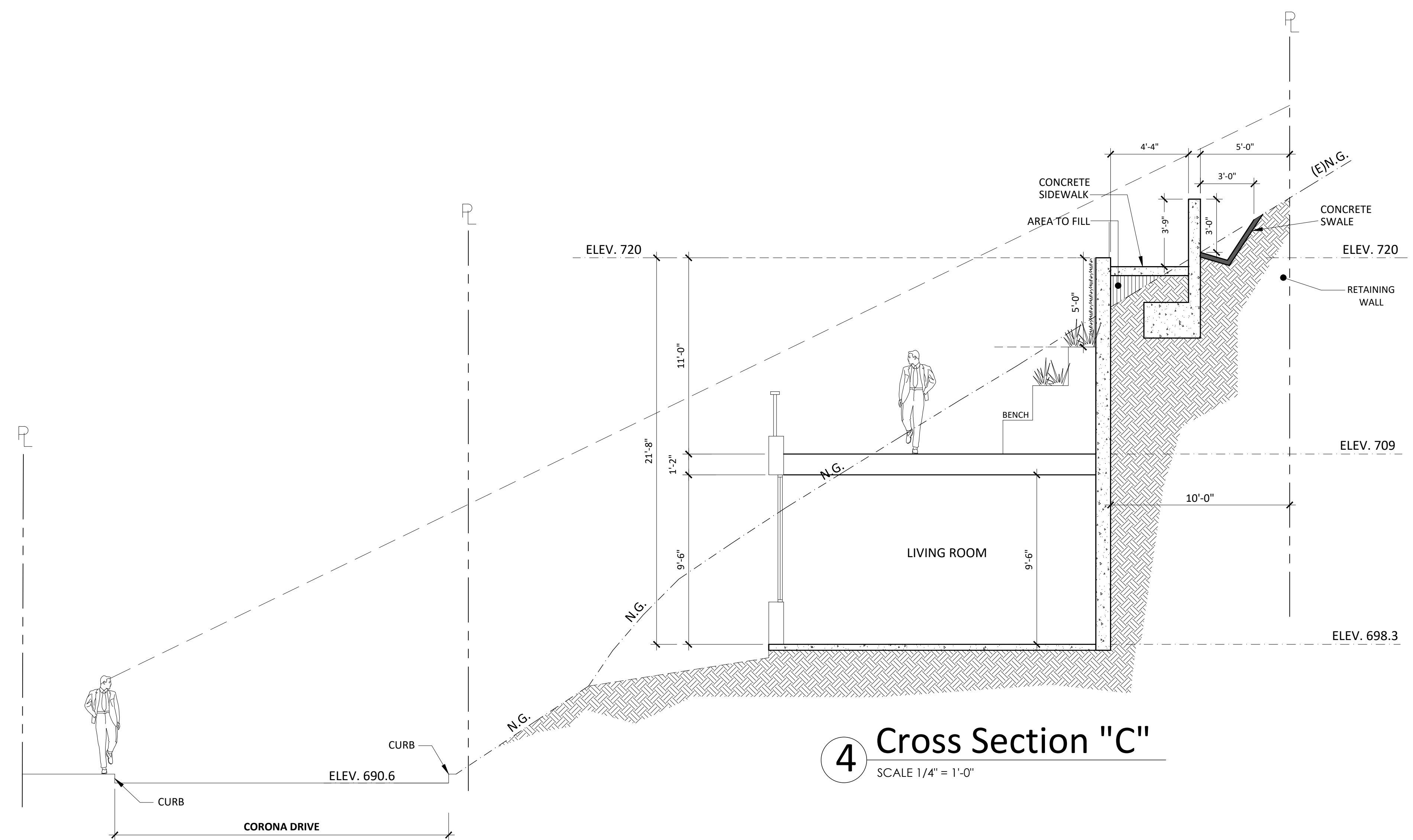

4 Cross Section "C"
 SCALE 1/4" = 1'-0"

10.25.19

REVISION

MARK DATE REVISIONS

| | | |
|---|--|--|
| △ | | |
| △ | | |
| △ | | |

EC + Associates
 e n g i n e e r i n g
 8207 BROOKGREEN ROAD
 DOWNEY, CA 90240
 P: 562 708 3586 P: 562 714 2886

OWNER:
 MR. EDUARDO J. CARRILLO
 ADDRESS:
 8207 BROOKGREEN RD.
 DOWNEY, CA 90240

PROPOSED
 NEW 2-STORY HOUSE
 PROJECT ADDRESS:
 1246 CORONA DR. GLENDALE, CA 91205
 VACANT LAND,
 GLENDALE CA 91205

CHECK AND VERIFY ALL
 DIMENSIONS BEFORE
 PROCEEDING WITH THE
 WORK. REPORT
 DISCREPANCIES TO THE
 ENGINEER. ALL
 CONSTRUCTION SHALL
 CONFORM TO THE C.B.C.

TITLE
 SITE CROSS
 SECTION E

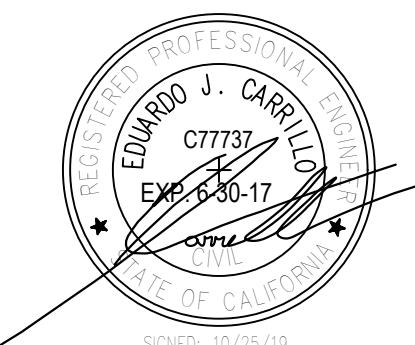

| | |
|-------------------------|------------------|
| JOB #: 15-000 | DRAWN: E.C. |
| DATE: 12 / 22 / 2016 | CHECKED: E.C. |

A-4.2
 SHEET OF

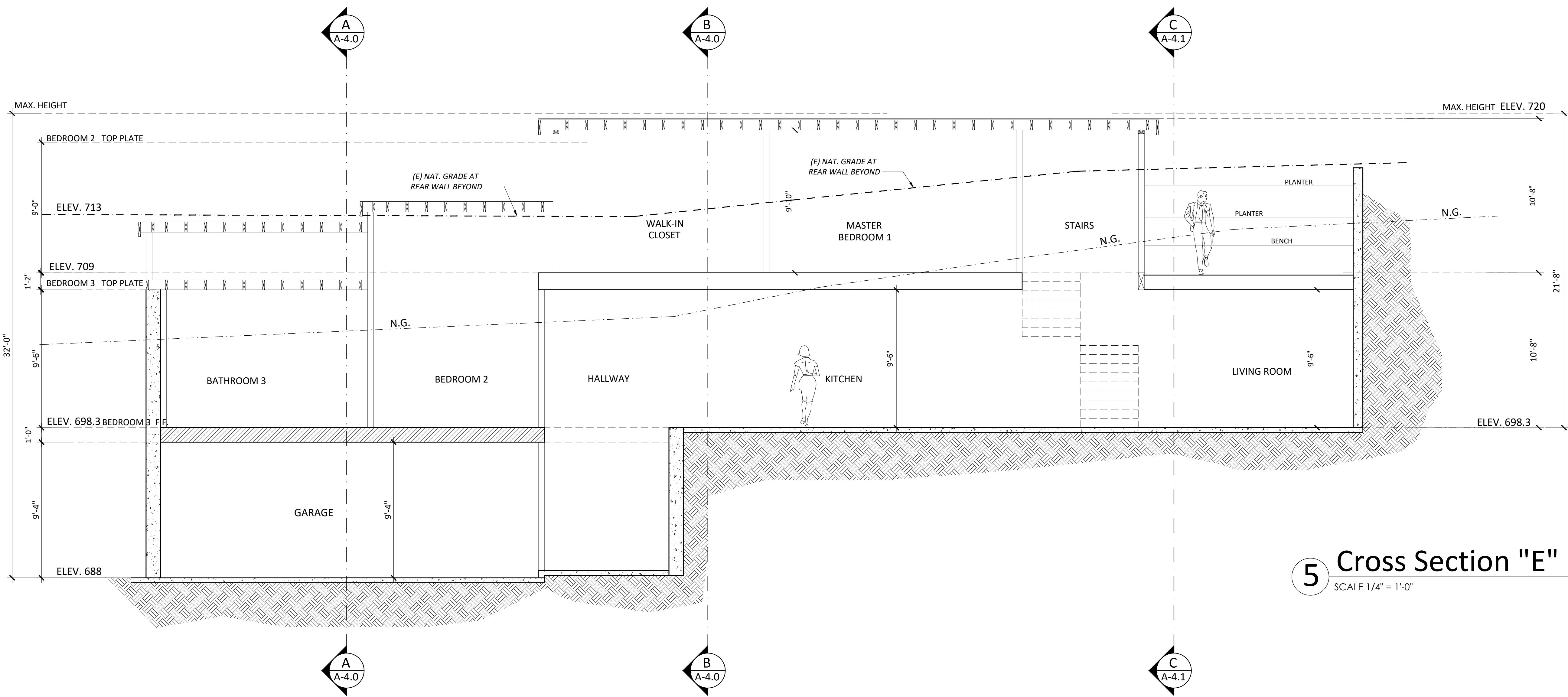

5 Cross Section "E"
 SCALE 1/4" = 1'-0"

10.25.19

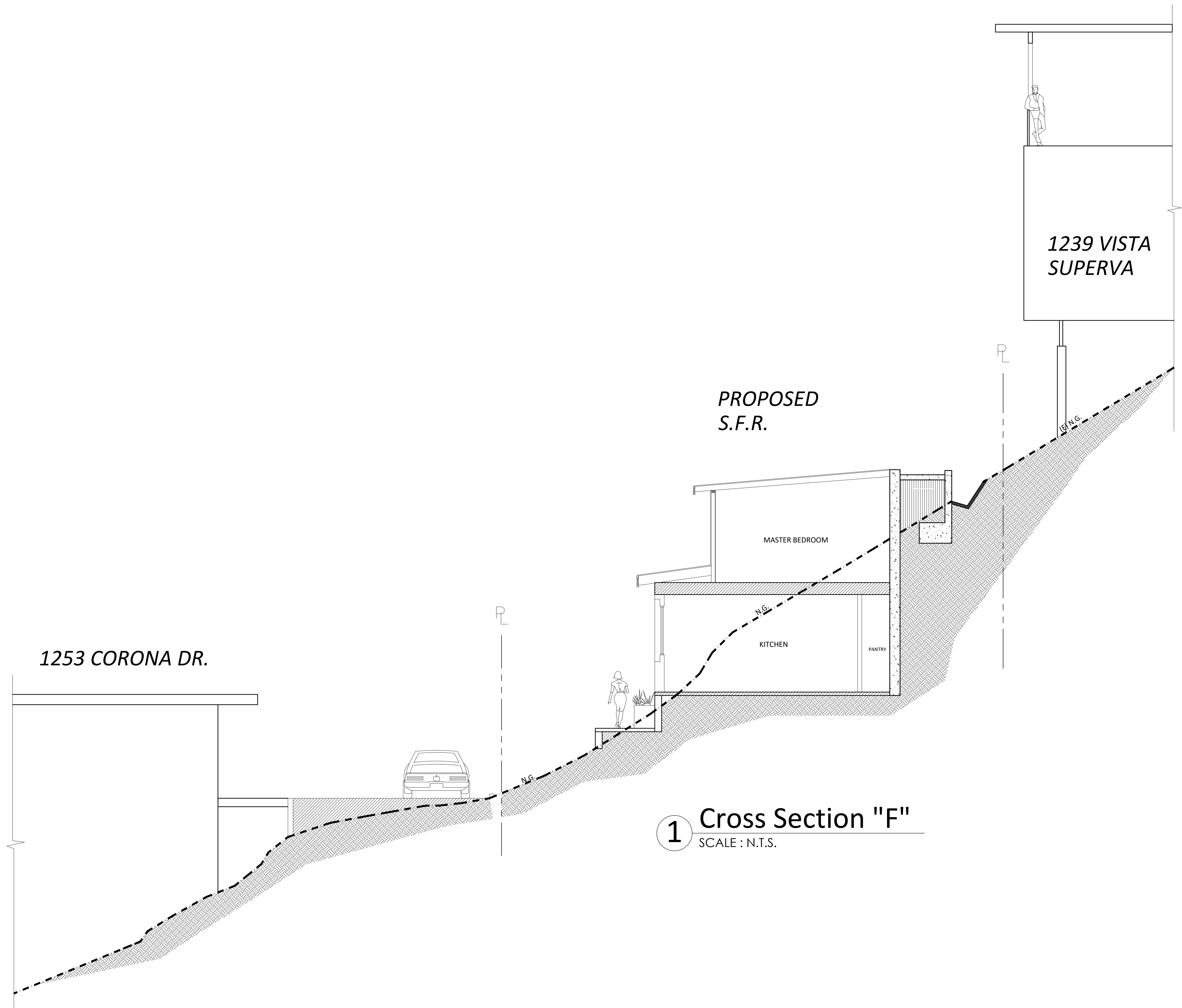

| REVISION | | |
|----------|------|-----------|
| MARK | DATE | REVISIONS |
| △ | | |
| △ | | |
| △ | | |

EC + Associates
 e n g i n e e r i n g
 8207 BROOKGREEN ROAD
 DOWNEY, CA 90240
 P: 562 708 3586 P: 562 714 2886

OWNER:
 MR. EDUARDO J. CARRILLO
 ADDRESS:
 8207 BROOKGREEN RD.
 DOWNEY, CA 90240

PROPOSED
 NEW 2-STORY HOUSE
 PROJECT ADDRESS:
 1248 CORONA DR. GLENDALE, CA 91205
 VACANT LAND,
 GLENDALE CA 91205

CHECK AND VERIFY ALL DIMENSIONS BEFORE PROCEEDING WITH THE WORK. REPORT DISCREPANCIES TO THE ENGINEER. ALL CONSTRUCTION SHALL CONFORM TO THE C.B.C.

TITLE
 SITE CROSS SECTION F



| | |
|-------------------------|------------------|
| JOB #: 15-000 | DRAWN: E.C. |
| DATE: 12 / 22 / 2016 | CHECKED: E.C. |

A-4.3
 SHEET OF





PRECISE GRADING PLAN

CARRILLO RESIDENCE

1248 CORONA DRIVE,
GLENDALE , CA. 91205

GENERAL NOTES

1. THE CONTRACTOR SHALL BE RESPONSIBLE FOR SURVEY MONUMENTS AND/OR VERTICAL CONTROL BENCHMARKS WHICH ARE DISTURBED OR DESTROYED BY CONSTRUCTION. A LAND SURVEYOR MUST FIELD LOCATE, REFERENCE, AND/OR PRESERVE ALL HISTORICAL OR CONTROLLING MONUMENTS PRIOR TO ANY EARTHWORK. IF DESTROYED, A LAND SURVEYOR SHALL REPLACE SUCH MONUMENTS WITH APPROPRIATE MONUMENTS. A CORNER RECORD OR RECORD OF SURVEY, AS APPROPRIATE, SHALL BE FILED AS REQUIRED BY THE PROFESSIONAL LAND SURVEYORS ACT, SECTION 8771 OF THE BUSINESS AND PROFESSIONS CODE OF THE STATE OF CALIFORNIA. IF ANY VERTICAL CONTROL IS TO BE DISTURBED OR DESTROYED, THE CITY OF ROSEMead PUBLIC WORKS DEPARTMENT MUST BE NOTIFIED, IN WRITING, AT LEAST 3 DAYS PRIOR TO THE CONSTRUCTION. THE CONTRACTOR WILL BE RESPONSIBLE FOR THE COST OF REPLACING ANY VERTICAL CONTROL BENCHMARKS DESTROYED BY THE CONSTRUCTION.
2. IMPORTANT NOTICE: SECTION 4216 OF THE GOVERNMENT CODE REQUIRES A DIG ALERT IDENTIFICATION NUMBER BE ISSUED BEFORE A "PERMIT TO EXCAVATE" WILL BE VALID. FOR YOUR DIG ALERT I.D. NUMBER, CALL UNDERGROUND SERVICE ALERT, TOLL FREE 1-800-227-2600, TWO DAYS BEFORE YOU DIG.
3. CONTRACTOR SHALL IMPLEMENT AN EROSION AND SEDIMENT CONTROL PROGRAM DURING THE PROJECT GRADING AND/OR CONSTRUCTION ACTIVITIES. THE PROGRAM SHALL MEET ALL APPLICABLE REQUIREMENTS OF THE STATE WATER RESOURCE CONTROL BOARD AND THE LOS ANGELES COUNTY AND STORM WATER STANDARDS MANUAL.
4. "PUBLIC IMPROVEMENT SUBJECT TO DESUETUDE OR DAMAGE." IF REPAIR OR REPLACEMENT OF SUCH PUBLIC IMPROVEMENTS IS REQUIRED, THE OWNER SHALL OBTAIN THE REQUIRED PERMITS FOR WORK IN THE PUBLIC RIGHT-OF-WAY, SATISFACTORY TO THE PERMIT- ISSUING AUTHORITY.
5. PRIOR TO ANY DISTURBANCE TO THE SITE, EXCLUDING UTILITY MARK-OUTS AND SURVEYING, THE CONTRACTOR SHALL MAKE ARRANGEMENTS FOR A PRE-CONSTRUCTION MEETING WITH THE CITY OF ROSEMead (626) 569-2100.
6. DEVIATIONS FROM THESE SIGNED PLANS WILL NOT BE ALLOWED UNLESS A CONSTRUCTION CHANGE IS APPROVED BY THE CITY ENGINEER OR THE CHANGE IS REQUIRED BY THE CITY INSPECTOR.
7. AS-BUILT DRAWINGS MUST BE SUBMITTED TO THE RESIDENT ENGINEER PRIOR TO ACCEPTANCE OF THIS PROJECT BY THE CITY.

SWPPP NOTES

1. DISCHARGING SEDIMENT-LADEN WATER WHICH WILL CAUSE OR CONTRIBUTE TO AN EXCEEDANCE OF THE APPLICABLE RWQCB'S BASIN PLANS FROM A DEWATERING SITE OR SEDIMENT BASIN/TRAP INTO ANY RECEIVING WATER OR STORM DRAIN WITHOUT FILTRATION OR EQUIVALENT TREATMENT IS PROHIBITED.
2. THE DISCHARGER SHALL AMEND THE SWPPP WHENEVER THERE IS A CHANGE IN CONSTRUCTION OR OPERATIONS, WHICH MAY AFFECT THE DISCHARGE OF POLLUTANTS TO SURFACE WATERS, GROUNDWATER, OR A MUNICIPAL STORM DRAIN SYSTEM. THE SWPPP SHALL ALSO BE AMENDED IF THE DISCHARGER VIOLATES ANY CONDITION OF THE GENERAL PERMIT OR HAS NOT ACHIEVED THE GENERAL OBJECTIVE OF REDUCING OR ELIMINATING POLLUTANTS IN STORM WATER DISCHARGES. ALL AMENDMENTS SHOULD BE DATED AND DIRECTLY ATTACHED TO THE SWPPP.
3. TEMPORARY ON-SITE DRAINAGE TO CARRY CONCENTRATED FLOW SHALL BE SELECTED TO COMPLY WITH CITY REQUIREMENTS TO CONTROL EROSION, TO RETURN FLOWS TO THEIR NATURAL DRAINAGE COURSES, AND TO PREVENT DAMAGE TO DOWNSTREAM PROPERTIES.
4. DISCHARGES ORIGINATING FROM OFF-SITE, WHICH FLOW ACROSS OR THROUGH AREAS DISTURBED BY CONSTRUCTION THAT MAY CONTAIN POLLUTANTS, SHOULD BE REPORTED TO THE RWQCB.
5. DISCHARGERS WHO ARE PRESENTLY COVERED UNDER NPDES GENERAL PERMIT NO. CAS000002 FOR DISCHARGE OF STORM WATER ASSOCIATED WITH CONSTRUCTION ACTIVITY MAY SUBMIT A NOTICE OF TERMINATION WHEN THEY MEET ONE OF THE FOLLOWING CRITERIA.
 - A. THE CONSTRUCTION PROJECT HAS BEEN COMPLETED AND THE FOLLOWING CONDITIONS HAVE BEEN MET: ALL ELEMENTS OF THE STORM WATER POLLUTION PREVENTION PLAN HAVE BEEN COMPLETED; CONSTRUCTION MATERIALS AND EQUIPMENT MAINTENANCE WASTE HAVE BEEN DISPOSED OF PROPERLY; THE SITE IS IN COMPLIANCE WITH ALL LOCAL STORM WATER MANAGEMENT REQUIREMENTS INCLUDING EROSION/SEDIMENT CONTROL REQUIREMENTS AND THE APPROPRIATE USE PERMITS HAVE BEEN OBTAINED; AND A POST-CONSTRUCTION STORM WATER OPERATION AND MANAGEMENT PLAN IS IN PLACE.
 - B. CONSTRUCTION ACTIVITIES HAVE BEEN SUSPENDED, EITHER TEMPORARILY OR INDEFINITELY AND THE FOLLOWING CONDITIONS HAVE BEEN MET: ALL ELEMENTS OF THE STORM WATER POLLUTION PREVENTION PLAN HAVE BEEN COMPLETED; CONSTRUCTION MATERIALS AND EQUIPMENT MAINTENANCE WASTE HAVE BEEN DISPOSED OF PROPERLY; ALL DENUDEd AREAS AND OTHER AREAS OF POTENTIAL EROSION ARE STABILIZED; AN OPERATION AND MAINTENANCE PLAN FOR EROSION AND SEDIMENT CONTROL IS IN PLACE; AND THE SITE IS IN COMPLIANCE WITH ALL LOCAL STORM WATER MANAGEMENT REQUIREMENTS INCLUDING EROSION/SEDIMENT CONTROL REQUIREMENTS. THE DATE CONSTRUCTION ACTIVITIES WERE SUSPENDED, AND THE EXPECTED DATE CONSTRUCTION ACTIVITIES WILL START UP AGAIN SHOULD BE PROVIDED.
6. SEDIMENT CONTROL BMP'S ARE REQUIRED AT APPROPRIATE LOCATIONS ALONG THE SITE PERIMETER AND AT ALL OPERATIONAL INTERNAL INLETS TO THE STORM DRAIN SYSTEM AT ALL TIMES.
7. THE CONTRACTOR IS RESPONSIBLE FOR ENSURING THAT ADEQUATE SEDIMENT CONTROL MATERIALS ARE AVAILABLE TO CONTROL SEDIMENT DISCHARGES AT THE DOWNGRADE PERIMETER AND OPERATIONAL INLETS (WEATHER AND STORM PREDICTIONS CAN BE OBTAINED BY CALLING THE NATIONAL WEATHER SERVICE AT (858) 675-8700 OR BY VISITING THE NATIONAL WEATHER SERVICE WEB SITE AT HTTP://WWW.WRH.NOAA.GOV FOR WEATHER INFORMATION AND CURRENT SATALITE/RADAR FEEDS).

8. INSPECTIONS SHALL BE PERFORMED BEFORE AND AFTER STORM EVENTS AND ONCE EACH 24-HOUR PERIOD DURING EXTENDED STORM EVENTS TO IDENTIFY BMP EFFECTIVENESS AND IMPLEMENT REPAIRS OR DESIGN CHANGES AS SOON AS FEASIBLE, DEPENDING ON FIELD CONDITIONS. EQUIPMENT, MATERIALS, AND WORKERS MUST BE AVAILABLE FOR RAPID RESPONSE TO FAILURES AND EMERGENCIES. ALL CORRECTIVE MAINTENANCE TO BMP'S SHALL BE PERFORMED AS SOON AS POSSIBLE AFTER THE CONCLUSION OF EACH STORM, DEPENDING UPON WORKER SAFETY.

9. FOR EACH INSPECTION, A QUALIFIED PERSON SHALL COMPLETE AN INSPECTION CHECKLIST CONTAINING THE FOLLOWING MINIMUM INFORMATION: INSPECTION DATE, WEATHER INFORMATION (BEGINNING/END OF STORM EVENT, DURATION, TIME SINCE LAST STORM, APPROXIMATE RAINFALL IN INCHES), DESCRIPTION OF INADEQUATE BMP'S, LIST OF OBSERVATIONS OF ALL BMP'S AND VISIBLE INSPECTION OF OUTFALLS, DISCHARGE POINTS, DOWNSTREAM LOCATIONS, AND PROJECTED REQUIRED MAINTENANCE ACTIVITIES, CORRECTIVE ACTIONS REQUIRED, INCLUDING CHANGES TO THE SWPPP AND IMPLEMENTATION DATES, INSPECTOR'S NAME, TITLE, SIGNATURE, AND QUALIFICATIONS.

10. INDIVIDUALS RESPONSIBLE FOR SWPPP IMPLEMENTATION, AND PERMIT COMPLIANCE SHALL BE APPROPRIATELY TRAINED. THIS INCLUDES THOSE PERSONNEL RESPONSIBLE FOR INSTALLATION, INSPECTION, MAINTENANCE, AND REPAIR OF BMP'S. THOSE RESPONSIBLE FOR OVERSEEING, REVISING, AND AMENDING THE SWPPP SHALL ALSO DOCUMENT THEIR TRAINING. THE QUALIFIED PERSON SHALL ATTEND THE PRE-CONSTRUCTION MEETING. THE QUALIFIED PERSON SHALL HAVE KNOWLEDGE AND TRAINING OF THE INTENT AND ENFORCEMENT OF SWPPP'S AND BMP'S AND BE PROPERLY TRAINED TO CONDUCT INSPECTIONS AND PREPARE REPORTS OF THE CONSTRUCTION SITE WITH RESPECT TO THE CITY'S MUNICIPAL CODE/ORDINANCES AND THE SWPPP.

11. THE CONTRACTOR SHALL MAINTAIN A COPY OF THE SWPPP AT THE CONSTRUCTION SITE, WHICH SHALL BE PROVIDED, UPON REQUEST, TO THE RWQCB OR CITY PERSONNEL. THE SWPPP IS CONSIDERED A REPORT THAT SHALL BE AVAILABLE TO THE PUBLIC BY THE RWQCB UNDER SECTION 308(B) OF THE CLEAN WATER ACT.

12. RECORDS OF ALL INSPECTIONS, COMPLIANCE CERTIFICATIONS, NONCOMPLIANCE REPORTING, SWPPP AND ANY OTHER DOCUMENTS GENERATED AS PART OF SWPPP, MUST BE RETAINED FOR A PERIOD OF AT LEAST THREE YEARS FROM THE DATE GENERATED.

GRADING & GEOTECHNICAL SPECIFICATIONS

1. ALL GRADING SHALL BE DONE UNDER OBSERVATION AND TESTING BY A QUALIFIED CIVIL ENGINEER OR GEOTECHNICAL ENGINEER AND, IF REQUIRED, BOTH A QUALIFIED CIVIL ENGINEER OR GEOTECHNICAL ENGINEER AND AN ENGINEERING GEOLOGIST. ALL GRADING MUST BE PERFORMED IN ACCORDANCE WITH APPLICABLE CITY ORDINANCE AND THE RECOMMENDATIONS AND SPECIFICATIONS SET FORTH IN THE SOILS REPORT OR GEOLOGICAL/GEOTECHNICAL INVESTIGATION ENTITLED:
 2. TRANSVERSE CONTRACTION JOINTS SHOULD NOT BE SPACED MORE THAN 15 FEET AND SHOULD BE CUT TO A DEPTH OF $\frac{1}{4}$ THE THICKNESS OF THE SLAB. LONGITUDINAL JOINTS SHOULD NOT BE SPACED MORE THAN 12 FEET APART.
 3. THE PCCP MATERIALS SHOULD CONFORM TO SECTION 201 AND SHOULD BE CONSTRUCTED IN ACCORDANCE WITH SECTION 302-6 OF THE STANDARD SPECIFICATIONS FOR PUBLIC WORKS CONSTRUCTION (SPPWC, LATEST EDITION). PAVEMENT SUBGRADE SHOULD BE PREPARED IN ACCORDANCE WITH SECTION 301 OF THE SPPWC
 4. EXISTING SOILS EXPOSED BELOW PAVEMENT REPLACEMENT AREAS SHOULD BE SCARIFIED AT LEAST 6 INCHES, MOISTURE CONDITIONED AS NEEDED TO NEAR OPTIMUM MOISTURE CONTENT, AND COMPACTED TO AT LEAST 95 PERCENT OF THE LABORATORY MAXIMUM DRY DENSITY (ASTM D 1557) TO PRODUCE A FIRM AND UNYIELDING SURFACE.
 5. IMPORTED AGGREGATE BASE MATERIAL SHOULD BE TESTED AND APPROVED BY THE GEOTECHNICAL CONSULTANT PRIOR TO PLACEMENT ABOVE THE SUBGRADE. AGGREGATE BASE MATERIALS SHOULD BE MOISTURE CONDITIONED AS NEEDED TO NEAR OPTIMUM MOISTURE CONTENT, AND COMPACTED TO AT LEAST 95 PERCENT OF THE LABORATORY MAXIMUM DRY DENSITY (ASTM D 1557) FOR SUPPORT OF NEW PAVEMENT SECTIONS.
 6. DURING CONSTRUCTION, THE GEOTECHNICAL ENGINEER AND/OR THEIR AUTHORIZED REPRESENTATIVES SHOULD BE PRESENT AT THE SITE TO PROVIDE A SOURCE OF ADVICE TO THE CLIENT REGARDING THE GEOTECHNICAL ASPECTS OF THE PROJECT AND TO OBSERVE AND TEST THE EARTHWORK PERFORMED. THEIR PRESENCE SHOULD NOT BE CONSTRUED AS AN ACCEPTANCE OF RESPONSIBILITY FOR THE PERFORMANCE OF THE COMPLETED WORK, SINCE IT IS THE SOLE RESPONSIBILITY OF THE CONTRACTOR PERFORMING THE WORK TO ENSURE THAT IT COMPLIES WITH ALL APPLICABLE PLANS, SPECIFICATIONS, ORDINANCES, ETC.
 7. AT THE COMPLETION OF THE GRADING OPERATIONS FOR THE EARTHWORK SHOWN ON THIS PLAN, AN AS-GRADED SOILS REPORT, OR IF REQUIRED, AN AS-GRADED GEOTECHNICAL REPORT WILL BE PREPARED IN ACCORDANCE WITH THE MOST RECENT EDITION OF THE CITY OF SAN DIEGO TECHNICAL GUIDELINES FOR GEOTECHNICAL REPORTS. THE FINAL "AS-GRADED" GEOTECHNICAL REPORT WILL BE SUBMITTED TO THE FIELD ENGINEERING SECTION OF ENGINEERING AND CAPITAL PROJECTS' DEPARTMENT AND A SECOND COPY TO THE GEOLOGY SECTION OF THE DEVELOPMENT SERVICES DEPARTMENT WITHIN 30 DAYS OF THE COMPLETION OF GRADING. WHERE GEOLOGIC INSPECTION IS INDICATED IN THE PERMIT OR PROJECT PLANS, REPORTS OR SPECIFICATIONS, THE FINAL REPORT MUST ALSO BE REVIEWED AND SIGNED BY A CALIFORNIA CERTIFIED ENGINEERING GEOLOGIST.
 8. THESE GRADING PLANS HAVE BEEN REVIEWED BY THE UNDERSIGNED AND FOUND TO BE IN CONFORMANCE WITH THE RECOMMENDATIONS AND SPECIFICATIONS CONTAINED IN THE REFERENCED GEOTECHNICAL REPORT(S) PREPARED FOR THIS PROJECT.

EROSION AND SEDIMENT CONTROL NOTES

TEMPORARY EROSION/SEDIMENT CONTROL, PRIOR TO COMPLETION OF FINAL IMPROVEMENTS, SHALL BE PERFORMED BY THE CONTRACTOR OR QUALIFIED PERSON AS INDICATED BELOW:

1. FOR STORM DRAIN INLETS, PROVIDE A GRAVEL BAG SILT BASIN IMMEDIATELY UPSTREAM OF INLET OR AS INDICATED ON DETAILS.
2. THE CONTRACTOR OR QUALIFIED PERSON SHALL BE RESPONSIBLE FOR CLEANUP OF SILT AND MUD ON ADJACENT STREET(S) AND STORM DRAIN SYSTEM DUE TO CONSTRUCTION ACTIVITY.
3. THE CONTRACTOR OR QUALIFIED PERSON SHALL CHECK AND MAINTAIN ALL LINED AND UNLINED DITCHES AFTER EACH RAINFALL.
4. THE CONTRACTOR SHALL REMOVE SILT AND DEBRIS AFTER EACH MAJOR RAINFALL.
5. EQUIPMENT AND WORKERS FOR EMERGENCY WORK SHALL BE MADE AVAILABLE AT ALL TIMES DURING THE RAINY SEASON. ALL NECESSARY MATERIALS SHALL BE STOCKPILED ON SITE AT CONVENIENT LOCATIONS TO FACILITATE RAPID CONSTRUCTION OF TEMPORARY DEVICES WHEN RAIN IS IMMINENT.
6. THE CONTRACTOR SHALL RESTORE ALL EROSION/SEDIMENT CONTROL DEVICES TO WORKING ORDER TO THE SATISFACTION OF THE CITY ENGINEER OR RESIDENT ENGINEER AFTER EACH RUN-OFF PRODUCING RAINFALL.
7. THE CONTRACTOR SHALL INSTALL ADDITIONAL EROSION/SEDIMENT CONTROL MEASURES AS MAY BE REQUIRED BY THE RESIDENT ENGINEER DUE TO UNCOMPLETED GRADING OPERATIONS OR UNFORESEEN CIRCUMSTANCES, WHICH MAY ARISE.
8. THE CONTRACTOR SHALL BE RESPONSIBLE AND SHALL TAKE NECESSARY PRECAUTIONS TO PREVENT PUBLIC TRESPASS ONTO AREAS WHERE IMPOUNDED WATERS CREATE A HAZARDOUS CONDITION.
9. ALL EROSION/SEDIMENT CONTROL MEASURES PROVIDED PER THE APPROVED GRADING PLAN SHALL BE INCORPORATED HEREON. ALL EROSION/SEDIMENT CONTROL FOR INTERIM CONDITIONS SHALL BE DONE TO THE SATISFACTION OF THE RESIDENT ENGINEER.
10. GRADED AREAS AROUND THE PROJECT PERIMETER MUST DRAIN AWAY FROM THE FACE OF THE SLOPE AT THE CONCLUSION OF EACH WORKING DAY.
11. ALL REMOVABLE PROTECTIVE DEVICES SHOWN SHALL BE IN PLACE AT THE END OF EACH WORKING DAY WHEN RAIN IS IMMINENT.
12. THE CONTRACTOR SHALL ONLY GRADE, INCLUDING CLEARING AND GRUBBING FOR THE AREAS FOR WHICH THE CONTRACTOR OR QUALIFIED PERSON CAN PROVIDE EROSION/SEDIMENT CONTROL MEASURES.
13. THE CONTRACTOR SHALL ARRANGE FOR WEEKLY MEETINGS DURING OCTOBER 1ST TO APRIL 30TH FOR PROJECT TEAM (GENERAL CONTRACTOR, QUALIFIED PERSON, EROSION CONTROL SUBCONTRACTOR IF ANY, ENGINEER OF WORK, OWNER/DEVELOPER AND THE RESIDENT ENGINEER) TO EVALUATE THE ADEQUACY OF THE EROSION/SEDIMENT CONTROL MEASURES AND OTHER RELATED CONSTRUCTION ACTIVITIES.

GRADING NOTES

1. GRADING AS SHOWN ON THESE PLANS SHALL BE IN CONFORMANCE WITH CURRENT STANDARD SPECIFICATIONS OF THE CITY AND THE COUNTY OF LOS ANGELES MUNICIPAL CODE.
2. GRADED, DISTURBED, OR ERODED AREAS THAT WILL NOT BE PERMANENTLY PAVED, COVERED BY STRUCTURE, OR PLANTED FOR A PERIOD OVER 90 DAYS SHALL BE TEMPORARILY RE-VEGETATED WITH A NON-IRRIGATED HYDROSEED MIX, GROUND COVER, OR EQUIVALENT MATERIAL.

OWNER/APPLICANT

MR. EDUARDO J. CARRILLO
1248 CORONA DR.,
GLENDALE CA., 91205





CONSTRUCTION NOTES

1. PROTECT IN PLACE AS NOTED.
2. CONSTRUCT 4" THICK PCC SLAB ON GRADE PER STRUCTURAL PLANS. SEE DETAIL "1" ON SHEET S1.1.

EXISTING IMPROVEMENTS

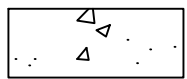
- WATER VALVE
- GAS VALVE
- WATER METER
- SEWER MANHOLE
- EXISTING TREE
- EXISTING ELEVATION.
- FINISHED ELEVATION.
- FIRE HYDRANT
- POWER POLE

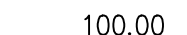
GRADING LEGEND

-  PROPOSED HARDSCAPE/DRIVE APPROACH
-  PROPOSED FLOW LINE
-  SPOT ELEVATION
-  RETAINING WALL

GRADING QUANTITIES

GRADED AREA..... 0.25 [ACRES]
CUT QUANTITIES..... 1098.47 [CYD] MAX CUT SLOPE RATIO (2:1)MAX
FILL QUANTITIES..... 39.98 [CYD] MAX FILL SLOPE RATIO (2:1)MAX

ASSESSORS PARCEL NUMBER

AS STATED ON RECORDED DOCUMENT

NOTICE TO CONTRACTOR

THE QUANTITIES AS SHOWN HEREON ARE FOR PERMIT & BONDING PURPOSES ONLY. THE CONTRACTOR SHALL BE RESPONSIBLE FOR VERIFICATION OF QUANTITIES PRIOR TO THE START OF GRADING & ACCOUNT FOR DISTRIBUTING ANY EXCESS MATERIAL OR SUPPLYING DEFICIENCIES TO BRING THE SITE TO DESIGN GRADE.

GRADING NOTES

SITE ADDRESS: VACANT LAND
GLENDALE, CA 91205
A.P.Ns. 5679-016-001
5679-016-002
5679-016-024

SCALE: AS SHOWN

CITY OF GLENDALE

PRECISE GRADING PLAN

CARRILLO RESIDENCE

1248 CORONA DRIVE,
GLENDALE, CA. 91205

LEGAL DESCRIPTION

LOTS 147, 148, AND 170 OF TRACT No. 6759, IN THE CITY OF GLENDALE, COUNTY OF LOS ANGELES, STATE OF CALIFORNIA, AS PER MAP RECORDED IN BOOK 91, PAGES 25-28 OF MAPS, IN THE OFFICE OF THE COUNTY RECORDER OF SAID COUNTY.

OWNER:

MR. EDUARDO J. CARRILLO
1248 CORONA DR.,
GLENDALE, CA., 91205

GENERAL NOTES:

- EXISTING LAND USE: RESIDENTIAL
- PROPOSED LAND USE: RESIDENTIAL
- EXISTING ADJACENT LAND USES TO THE EAST AND WEST: RESIDENTIAL

DEVELOPMENT STANDARDS:

| DESCRIPTION | PROVIDED |
|--------------------|----------|
| BUILDING SETBACKS: | |
| FRONT | 20.0' |
| SIDE | 12.5' |
| REAR | 10.0' |
| PARKING SPACES: | 2 GARAGE |

INFRASTRUCTURE NOTE:

LOCATION AND SIZE OF INFRASTRUCTURE SHOWN HEREON ARE BASED ON ARCHITECTURAL.

AREA SUMMARY:

| DESCRIPTION | SQUARE FEET | ACRES | PERCENTAGE |
|---------------|-------------|----------|------------|
| AREA | 8,889 SF | 0.204 AC | 20.4% |
| OPEN SPACE | 5,574 SF | 0.127 AC | 12.7% |
| BUILDING AREA | 2,844 SF | 0.065 AC | 6.5% |
| DRIVEWAY | 450 SF | 0.010 AC | 7.5% |

CONSTRUCTION NOTES

- PROTECT IN PLACE AS NOTED.
- CONSTRUCT 4" THICK PCC SLAB ON GRADE PER STRUCTURAL PLANS. SEE DETAIL "1" ON SHEET S1.1.

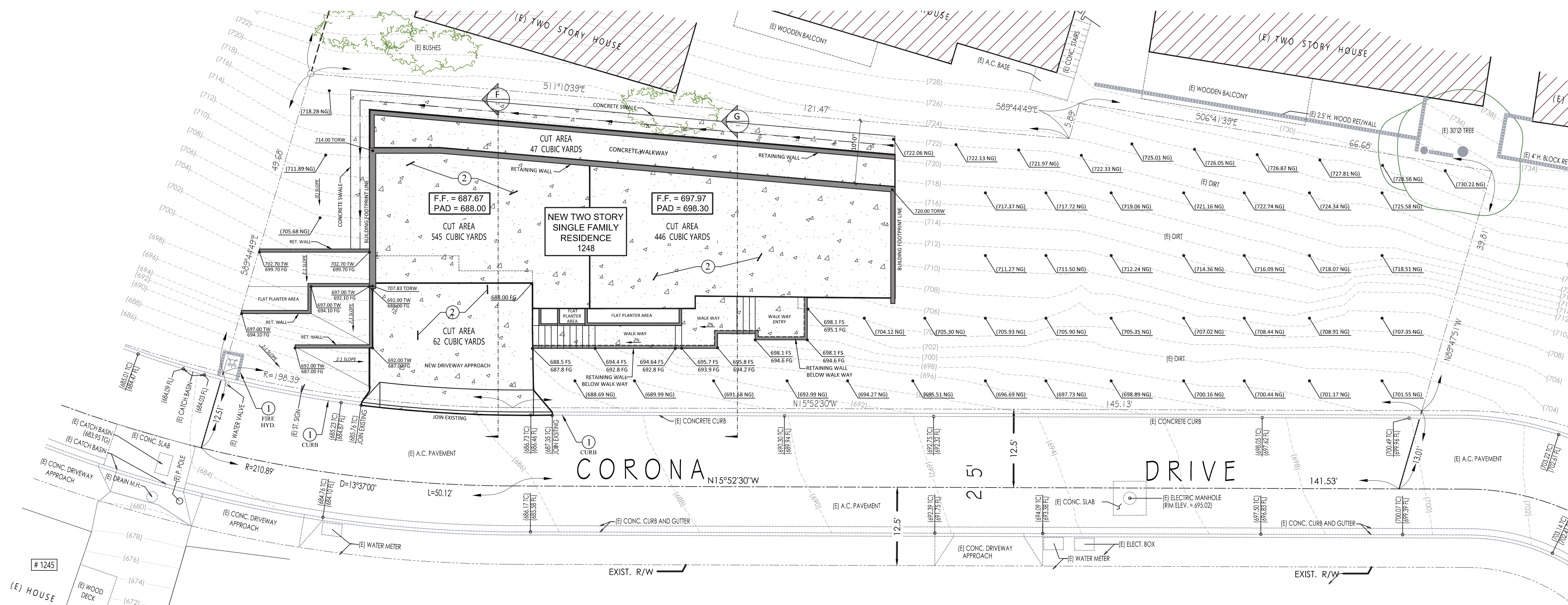

GRADING PLAN
SCALE: 1" = 10'

GRADING LEGEND

- PROPOSED HARDSCAPE/DRIVE APPROACH
- PROPOSED FLOW LINE
- SPOT ELEVATION
- RETAINING WALL

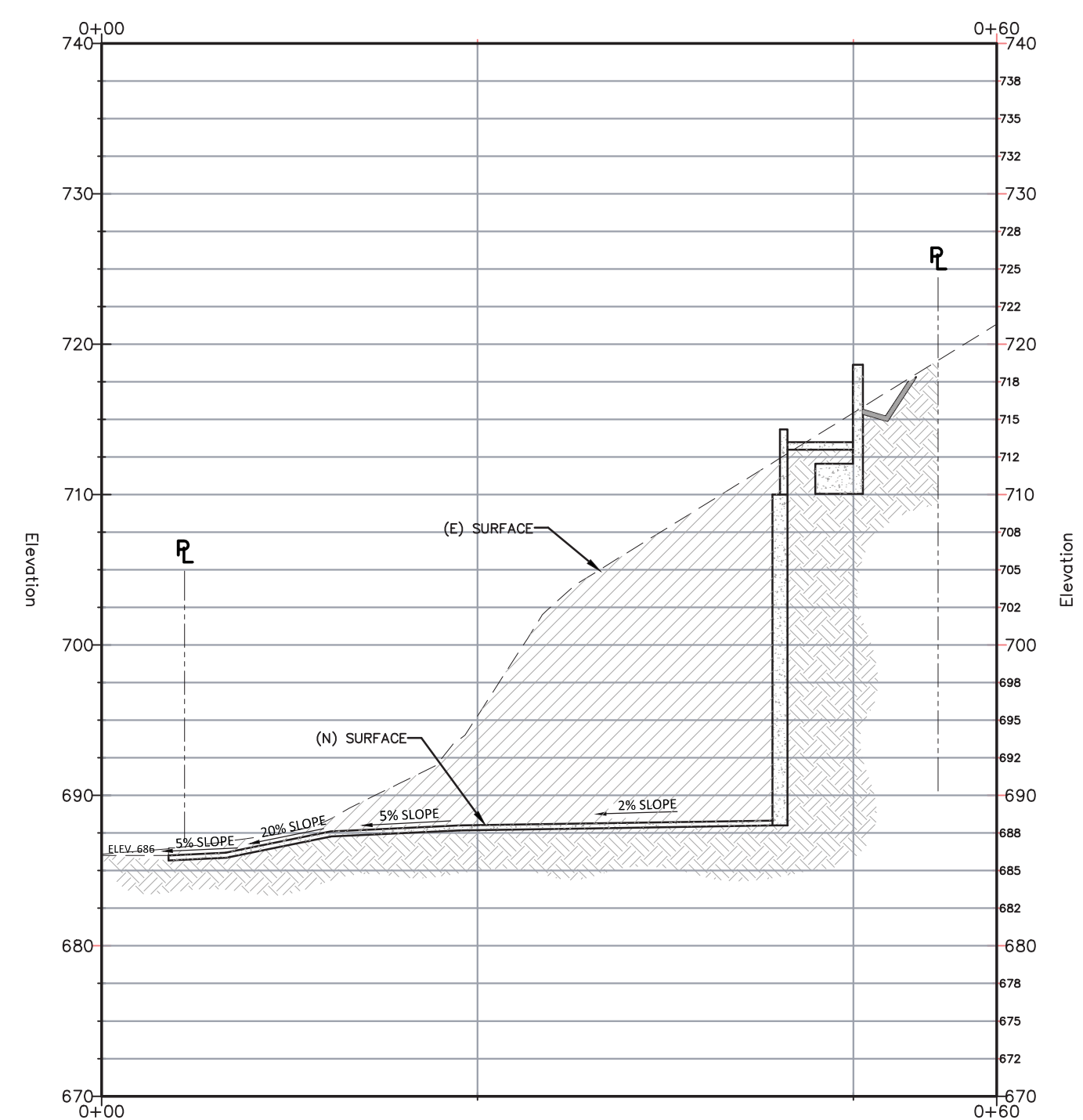

SECTION F-F
SCALE: 1" = 20'

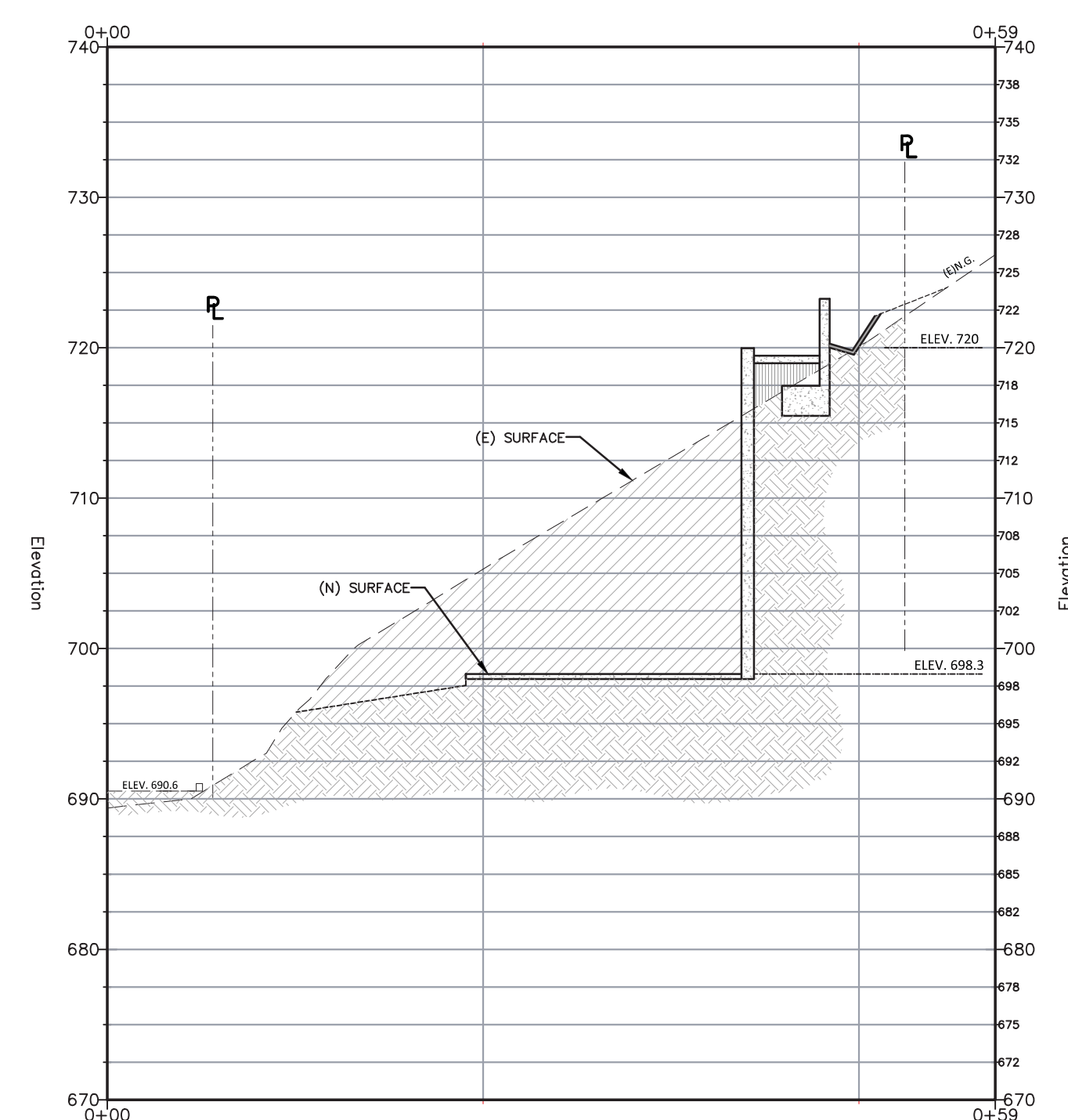

SECTION G-G
SCALE: 1" = 20'

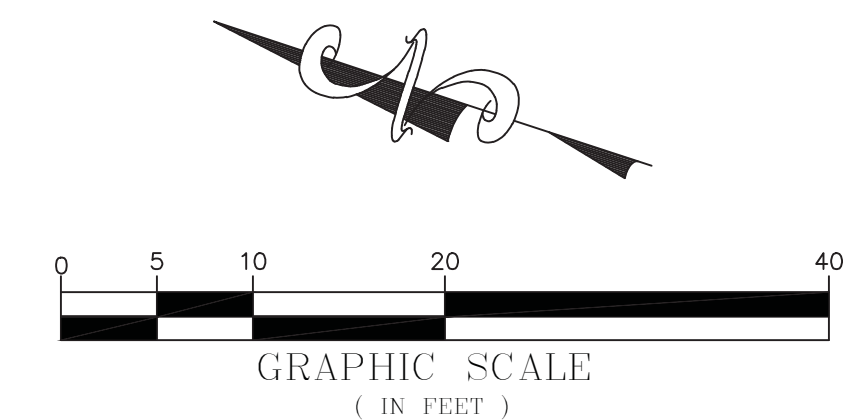

| GRADING PLAN | |
|------------------|---|
| SITE ADDRESS: | VACANT LAND GLENDALE, CA 91205 A.P.Ns. 5679-016-001 5679-016-002 5679-016-024 |
| SCALE: | AS SHOWN |
| CITY OF GLENDALE | |

Cut/Fill Report

Generated: 2019-12-30 11:24:47

By user: David Cervantes

Drawing: J:\2019 Projects\jn198-1248 Corona ave\Drawings\XrefJ:\2019 Projects\jn198-1248 Corona ave\Drawings\Xref\X_TOPO.dwg

| Volume Summary | | | | | | | |
|---------------------|------|------------|-------------|-------------------|---------------|----------------|---------------|
| Name | Type | Cut Factor | Fill Factor | 2d Area (Sq. Ft.) | Cut (Cu. Yd.) | Fill (Cu. Yd.) | Net (Cu. Yd.) |
| Retaining Wall (1) | full | 1.000 | 1.000 | 434.68 | 46.98 | 0.07 | 46.91<Cut> |
| First Floor Pad (1) | full | 1.000 | 1.000 | 1838.70 | 445.56 | 38.83 | 406.73<Cut> |
| Driveway (1) | full | 1.000 | 1.000 | 515.97 | 61.48 | 1.08 | 60.40<Cut> |
| Garage Pad (1) | full | 1.000 | 1.000 | 837.66 | 544.46 | 0.00 | 544.46<Cut> |

| Totals | | | | |
|--------|-------------------|---------------|----------------|---------------|
| | 2d Area (Sq. Ft.) | Cut (Cu. Yd.) | Fill (Cu. Yd.) | Net (Cu. Yd.) |
| Total | 3627.02 | 1098.47 | 39.98 | 1058.49<Cut> |

* Value adjusted by cut or fill factor other than 1.0

| MARK | DATE | REVISIONS |
|------|------|-----------|
| 1 | | |
| 2 | | |
| 3 | | |

EC + Associates
 engineering
 8207 BROOKGREEN ROAD
 DOWNEY, CA 90240
 P: 562 708 3586

OWNER:
 MR. EDUARDO J. CARRILLO
 ADDRESS:
 1248 CORONA DR.
 GLENDALE, CA 91205

PROJECT ADDRESS:
 1248 CORONA DR.
 GLENDALE, CA 91205

CHECK AND VERIFY ALL DIMENSIONS BEFORE PROCEEDING WITH THE WORK. REPORT DISCREPANCIES TO THE ENGINEER. ALL CONSTRUCTION SHALL CONFORM TO THE C.B.C.

TITLE
 FOUNDATION AND FLOOR FRMG. PLAN

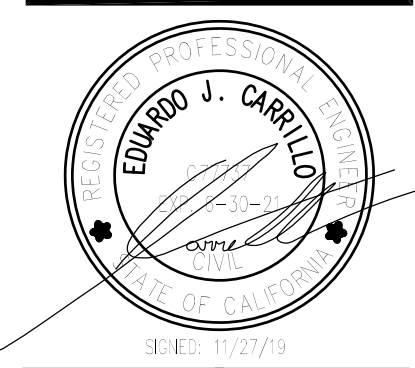

| | |
|----------------------|------------------|
| JOB #: 19-184 | DRAWN: U.P. |
| DATE: Nov. 27, 19 | CHECKED: E.C. |

S2.1
 SHEET X OF X

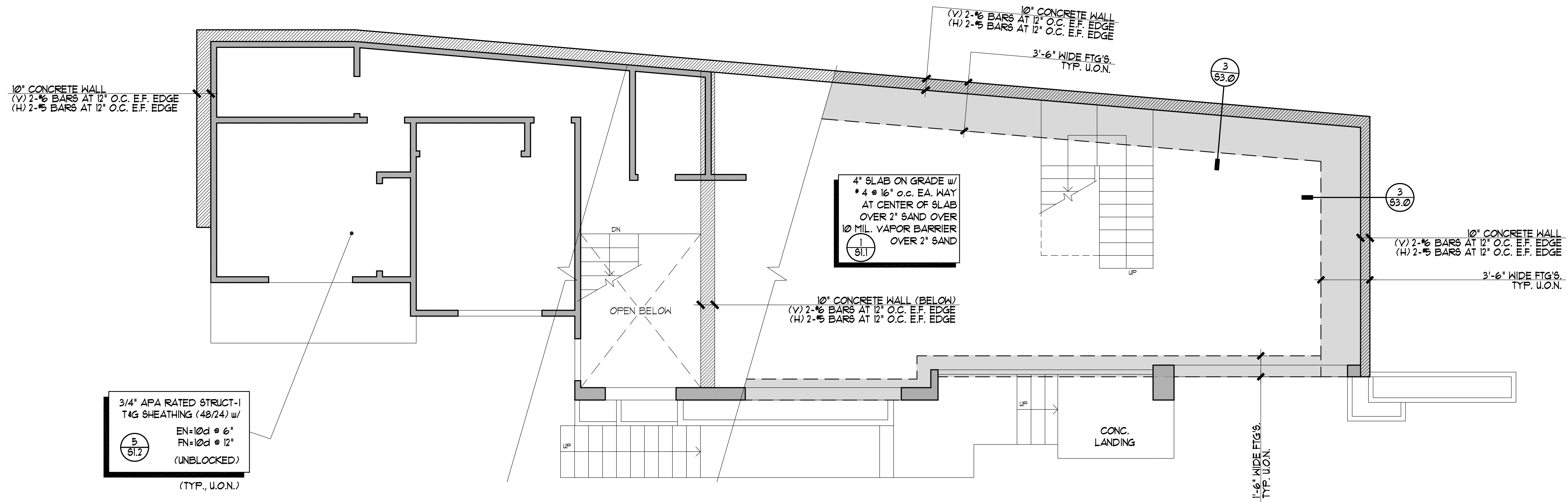

FOUNDATION AND FLOOR FRAMING PLAN

scale: 1/4"=1'-0"

PLAN NOTES (SEE NOTES ON S2.0 FOR FND.)

- SEE GENERAL NOTES AND TYPICAL DETAILS ON SHEETS S1.0, S1.1, S1.2, S1.3 & S1.4. THESE NOTES AND DETAILS SHALL BE USED WHERE APPLICABLE WHETHER SPECIFICALLY REFERENCED OR NOT.
- FOR TOP OF SHEATHING, TOP PLATE, AND TOP OF PARAPET ELEVATIONS NOT NOTED, REFER TO ARCHITECTURAL DRAWINGS.
- STRUCTURAL WALLS ARE WALLS THAT RESIST GRAVITY, WIND, AND/OR SEISMIC LOADS. ALL EXTERIOR WOOD FRAME WALLS ARE STRUCTURAL WALLS. WALLS OR PORTIONS OF WALLS NOT INDICATED ON THE STRUCTURAL DRAWINGS ARE PARTITION WALLS. REFER TO ARCHITECTURAL PLANS FOR LOCATION AND EXTENT OF PARTITION WALLS.
- FOR DIMENSIONS, EXTENT, AND NATURE OF ALL WALLS, REFER TO ARCHITECTURAL DWGS.
- NOMINAL ROOF LINE VARIES. SEE PLAN FOR SPOT ELEVATIONS. STRUCTURAL WALLS BELOW ARE INDICATED BY DASHED LINES. FRAMING AT THIS LEVEL ARE SHOWN BY SOLID LINES.
- SIZE AND LOCATION OF ALL MECHANICAL EQUIPMENT TO BE REVIEWED AND APPROVED BY THE STRUCTURAL ENGINEER PRIOR TO PLACEMENT.
- FOR SIZE AND LOCATION OF FLOOR OPENING FOR STAIRS, REFER TO ARCHITECTURAL DWGS.
- FOR TOP OF SHEATHING ELEVATIONS NOT NOTED REFER TO ARCHITECTURAL DWGS.
- ALL EXISTING FRAMING, DIMENSIONS, FOOTINGS TO BE VERIFY BY CONTRACTOR PRIOR TO COMMENCING ANY WORK. NOTIFY THE ENGINEER OF RECORDS IF ANY DISCREPANCIES OCCURS.
- ALL WOOD EXPOSED TO WEATHER TO BE TREATED WOOD, REDWOOD OR OTHER SPECIES NATURALLY RESISTANT TO DECAY AND JOIST HANGERS, STRAPS, TIES, ETC. SHALL BE GALVANIZED (G185 COATING). FASTENERS SHALL BE STAINLESS STEEL OR APPROVED EQUAL.

LEGEND

- WOOD POST SIZE. MARK IS INDICATED AT THE BASE OF THE POST.
- STRAP HOLD-DOWN SIZE AT THAT FLOOR LEVEL. SEE SCHEDULE ON THIS SHEET.
- SHEARWALL PER SCHEDULE ON S2.0. SEE DETAILS ON SHEET S1.2 FOR TYPICAL SHEARWALL ASSEMBLY. ALL SHEARWALLS CALLED OUT AT THIS LEVEL START AT THIS LEVEL AND CONTINUE UP.
- REQUIRED TOP PLATE SPLICE. SEE SCHEDULE ON S1.2 FOR ALL REQUIREMENTS. THE MARKED SPLICE SHALL APPLY FOR THE FULL LENGTH OF THE WALL WHERE INDICATED. USE TYPE [] SPLICE MIN., U.O.N. ON PLAN.
- FRAMING MEMBER BEARING ON TOP OF SUPPORT.
- FRAMING MEMBER INSTALLED FLUSH (IN HANGER) AT ITS SUPPORT.
- HEADER MEMBER. INSTALL MEMBER AT HEAD OF OPENING IN WALL BELOW. SEE DETAIL S1.3.
- BEAM MEMBER INSTALLED DIRECTLY BELOW SHEATHING, U.O.N.

STRAP HD SCHEDULE

| TAG | STRAP TYPE | END LENGTH "L1" | NAILS REQ. WITHIN END LENGTH "L1" | CAPACITY (KIPS) | LA CITY (KIPS) | EQUIVALENT HOLD-DOWN @ FOUNDATION |
|------|------------|-----------------|-----------------------------------|-----------------|----------------|-----------------------------------|
| ST-1 | CS18 | 10" | 10 - 10d | 1.37 | 1.03 | HDU2 |
| ST-2 | CS16 | 12" | 11 - 10d | 1.705 | 1.27 | HDU2 |
| ST-3 | 2-CS18 | 10" | 20 - 10d | 2.74 | 2.05 | HDU2 |
| ST-4 | 2-CS16 | 12" | 22 - 10d | 3.41 | 2.56 | HDU4 |
| ST-5 | CMSTC16 | 23" | 33 - 16d SINKERS | 4.59 | 3.44 | HDU5 |
| ST-6 | CMST14 | 30" | 38 - 16d | 6.49 | 4.86 | HDU8 |
| ST-7 | CMST12 | 39" | 50 - 16d | 9.24 | 6.93 | HDU11 |

- NOTES:
- STRAP CONNECTION PER DETAIL 6 ON SHEET S1.4.
 - SEE DETAILS T & B ON SHEET S1.4. FOR STRAP TO BEAM CONDITIONS.
 - BASED ON LARR 2513 AND ICC ER 2105
 - HOLD-DOWN IS REQ'D AT FOUNDATION AT EA. FLOOR TO FLOOR STRAP/POST. SEE EQUIVALENT HD IN TABLE FOR HD'S TO FOUNDATION DETAIL ON SCHEDULE ABOVE.
 - INSTALL STRAP OVER SHEATHING. SHEATHING EDGE NAILING REQ'D IN ADDITION TO STRAP NAILING

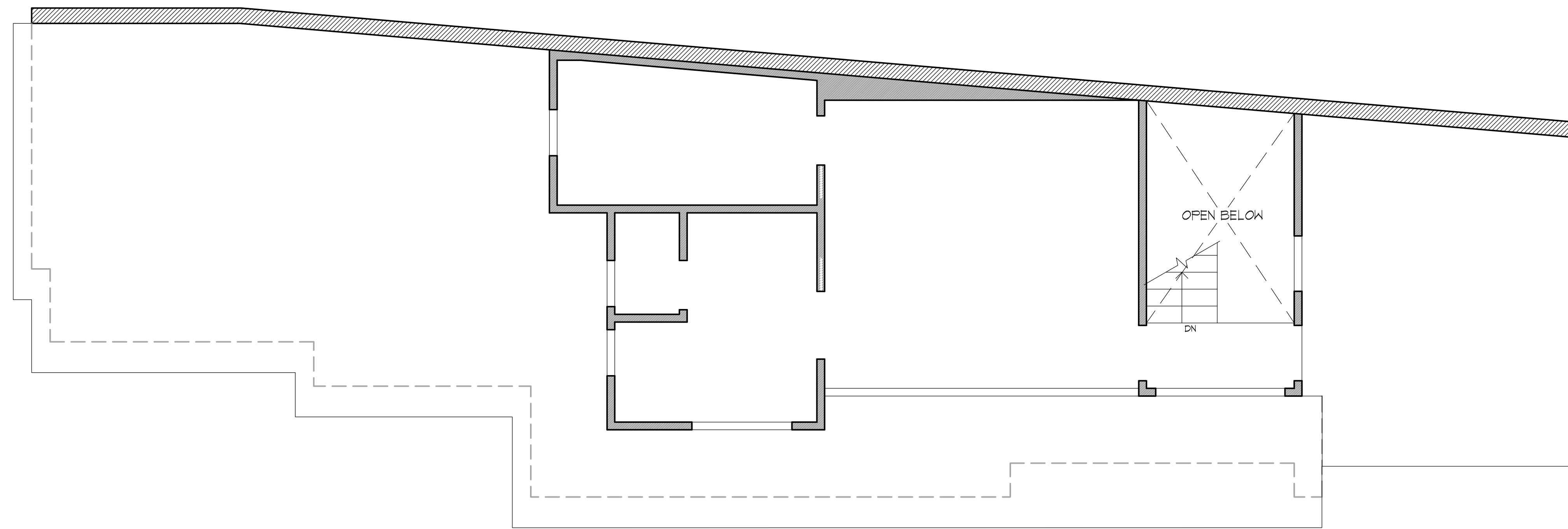

ROOF FRAMING PLAN

scale: 1/4"=1'-0"

PLAN NOTES

- SEE GENERAL NOTES AND TYPICAL DETAILS ON SHEETS S1.0, S1.1, S1.2, S1.3 & S1.4. THESE NOTES AND DETAILS SHALL BE USED WHERE APPLICABLE WHETHER SPECIFICALLY REFERENCED OR NOT.
- FOR TOP OF SHEATHING, TOP PLATE, AND TOP OF PARAPET ELEVATIONS NOT NOTED, REFER TO ARCHITECTURAL DRAWINGS.
- STRUCTURAL WALLS ARE WALLS THAT RESIST GRAVITY, WIND, AND/OR SEISMIC LOADS. ALL EXTERIOR WOOD FRAME WALLS ARE STRUCTURAL WALLS. WALLS OR PORTIONS OF WALLS NOT INDICATED ON THE STRUCTURAL DRAWINGS ARE PARTITION WALLS. REFER TO ARCHITECTURAL PLANS FOR LOCATION AND EXTENT OF PARTITION WALLS.
- FOR DIMENSIONS, EXTENT, AND NATURE OF ALL WALLS, REFER TO ARCHITECTURAL DWGS.
- NOMINAL ROOF LINE VARIES. SEE PLAN FOR SPOT ELEVATIONS. STRUCTURAL WALLS BELOW ARE INDICATED BY DASHED LINES. FRAMING AT THIS LEVEL ARE SHOWN BY SOLID LINES.
- SIZE AND LOCATION OF ALL MECHANICAL EQUIPMENT TO BE REVIEWED AND APPROVED BY THE STRUCTURAL ENGINEER PRIOR TO PLACEMENT.
- ALL WOOD EXPOSED TO WEATHER TO BE TREATED WOOD, REDWOOD OR OTHER SPECIES NATURALLY RESISTANT TO DECAY AND JOIST HANGERS, STRAPS, TIES, ETC. SHALL BE GALVANIZED (G185 COATING). FASTENERS SHALL BE STAINLESS STEEL OR APPROVED EQUAL.
- ALL EXISTING FRAMING, DIMENSIONS, FOOTINGS TO BE VERIFY BY CONTRACTOR PRIOR TO COMMENCING ANY WORK. NOTIFY THE ENGINEER OF RECORDS IF ANY DISCREPANCIES OCCURS.

LEGEND

- REQUIRED TOP PLATE SPLICE. SEE SCHEDULE ON 9/S1.2 FOR ALL REQUIREMENTS. THE MARKED SPLICE SHALL APPLY FOR THE FULL LENGTH OF THE WALL WHERE INDICATED. USE TYPE [S] SPLICE MIN. U.N.O. ON PLAN.
- FRAMING MEMBER BEARING ON TOP OF SUPPORT.
- FRAMING MEMBER INSTALLED FLUSH (IN HANGER) AT ITS SUPPORT.
- HEADER MEMBER. INSTALL MEMBER AT HEAD OF OPENING IN WALL BELOW. SEE DETAIL 9/S1.3.
- BEAM MEMBER INSTALLED DIRECTLY BELOW SHEATHING, U.O.N.
- CEILING JOIST CLEAR SPAN, SEE DETAIL 12/S1.3 FOR CEILING JOIST SIZE AND SPACING.
- 'CM612' COIL STRAP (L=15FT MIN. U.N.O.) w/ CONT. 4x JOIST DEPTH CONT. BLK'G, PER DETAIL.

REVISION

| MARK | DATE | REVISIONS |
|------|------|-----------|
| 1 | | |
| 2 | | |
| 3 | | |

EC + Associates
 engineering
 8207 BROOKGREEN ROAD
 DOWNEY, CA 90240
 P: 562 708 3586

OWNER:
 MR. EDUARDO J. CARRILLO
 ADDRESS:
 1248 CORONA DR.
 GLENDALE, CA 91205

PROJECT ADDRESS:
 1248 CORONA DR.
 GLENDALE, CA 91205

CHECK AND VERIFY ALL DIMENSIONS BEFORE PROCEEDING WITH THE WORK. REPORT DISCREPANCIES TO THE ENGINEER. ALL CONSTRUCTION SHALL CONFORM TO THE C.B.C.

TITLE
 ROOF FRMG.
 PLAN

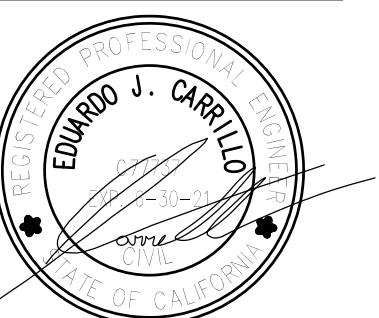

| | |
|----------------------|------------------|
| JOB #: 19-184 | DRAWN: U.P. |
| DATE: Nov. 27, 19 | CHECKED: E.C. |

S2.2
 SHEET X OF X

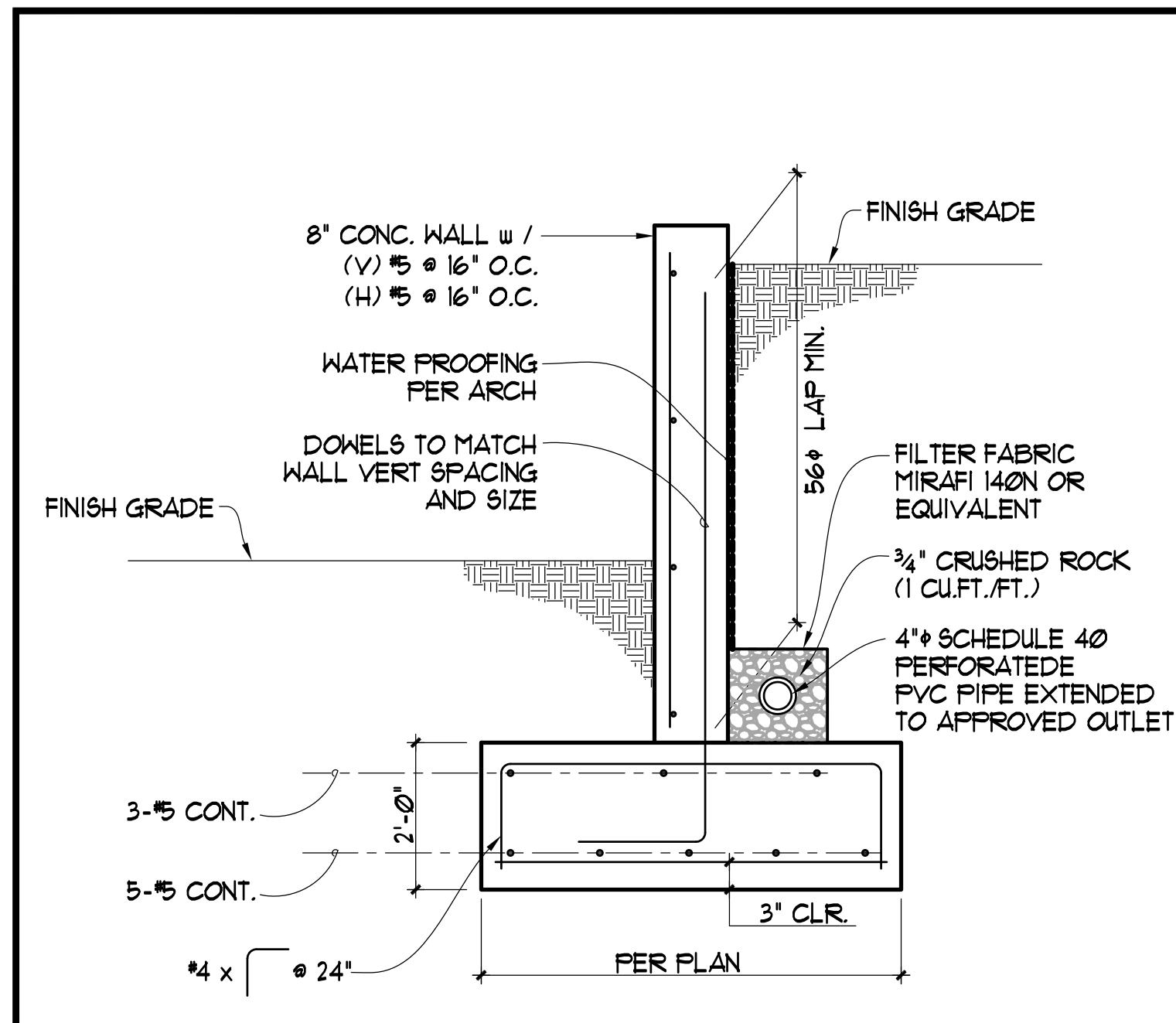

4 DETAIL

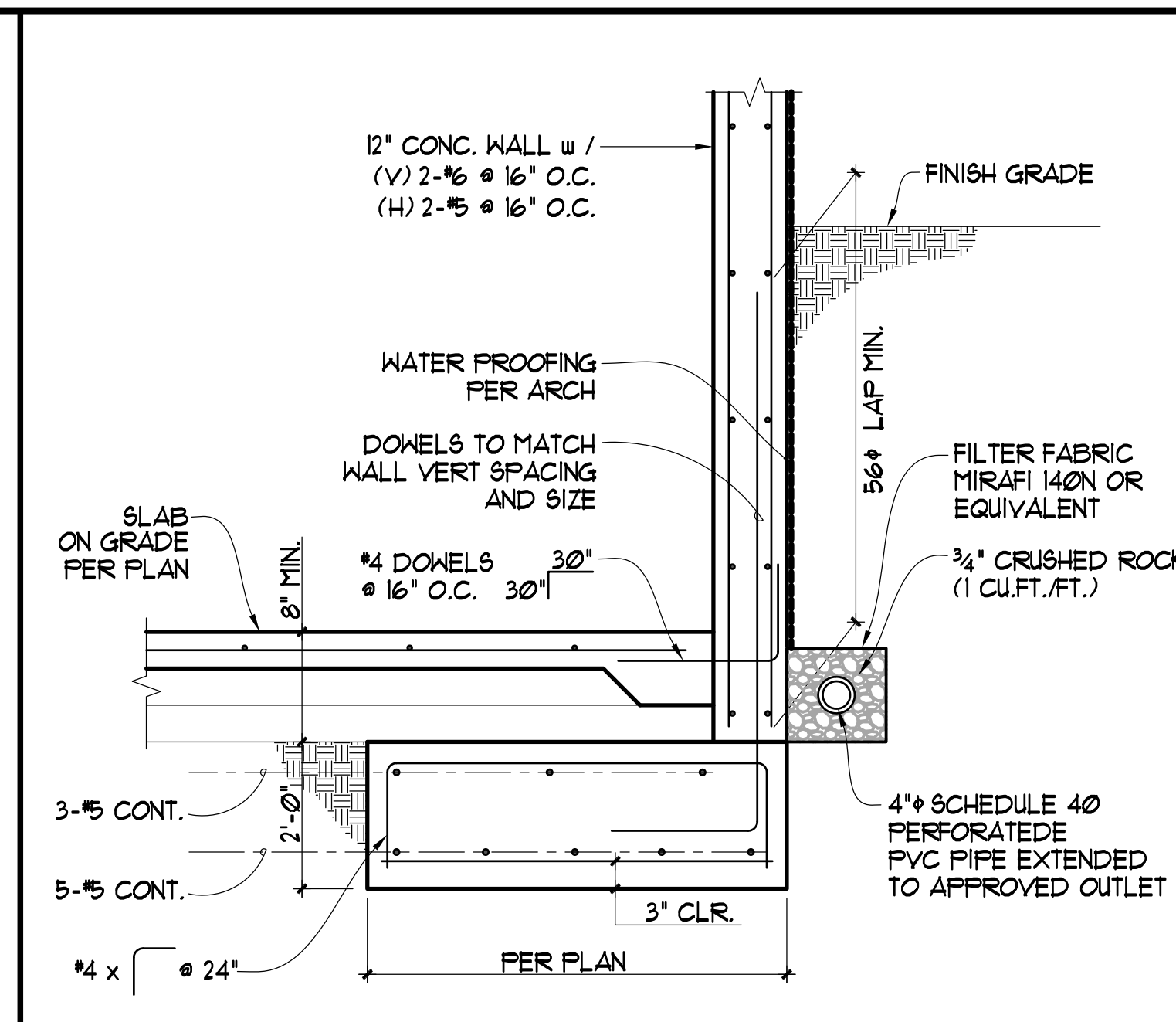

3 DETAIL

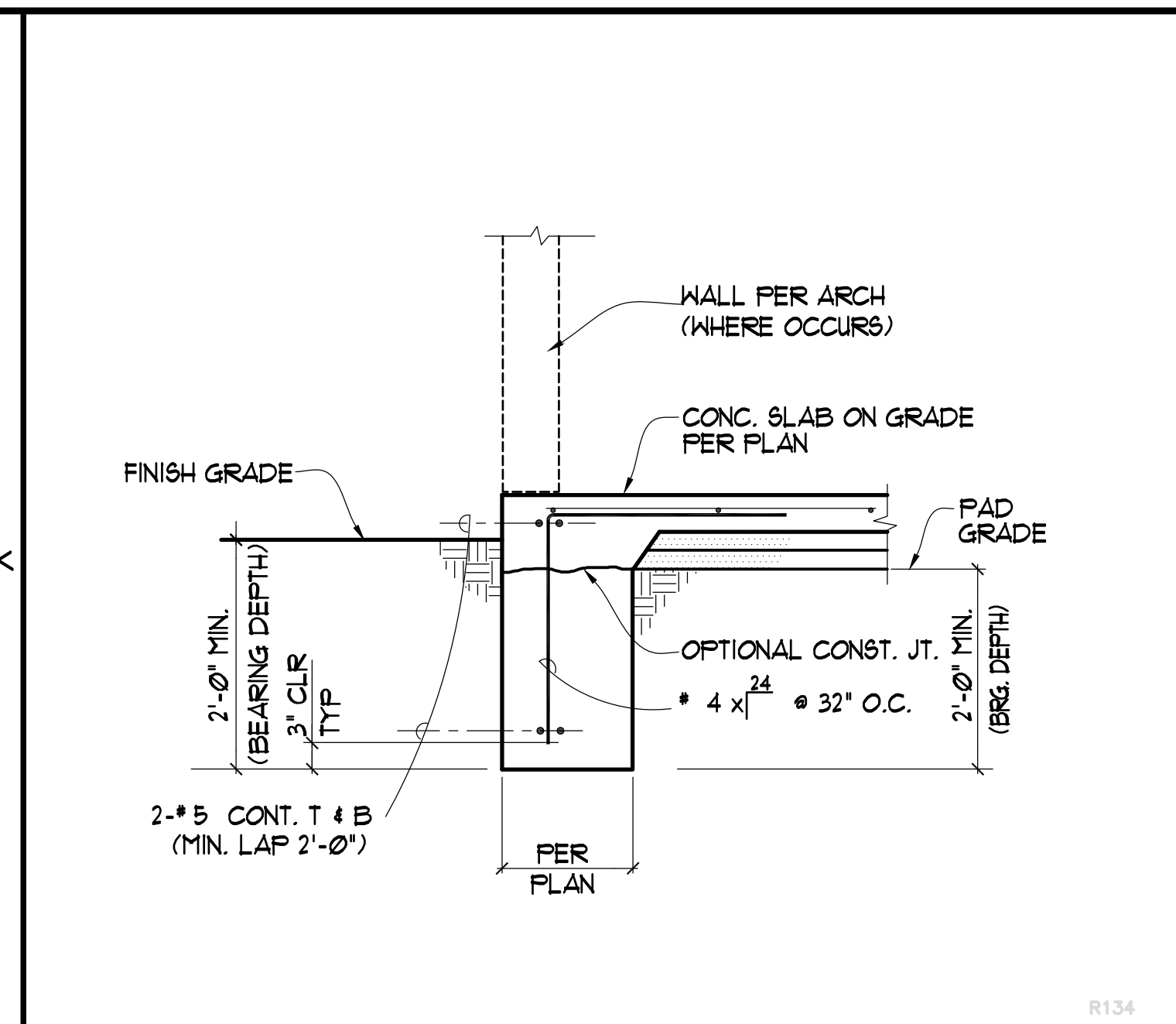

2 DETAIL

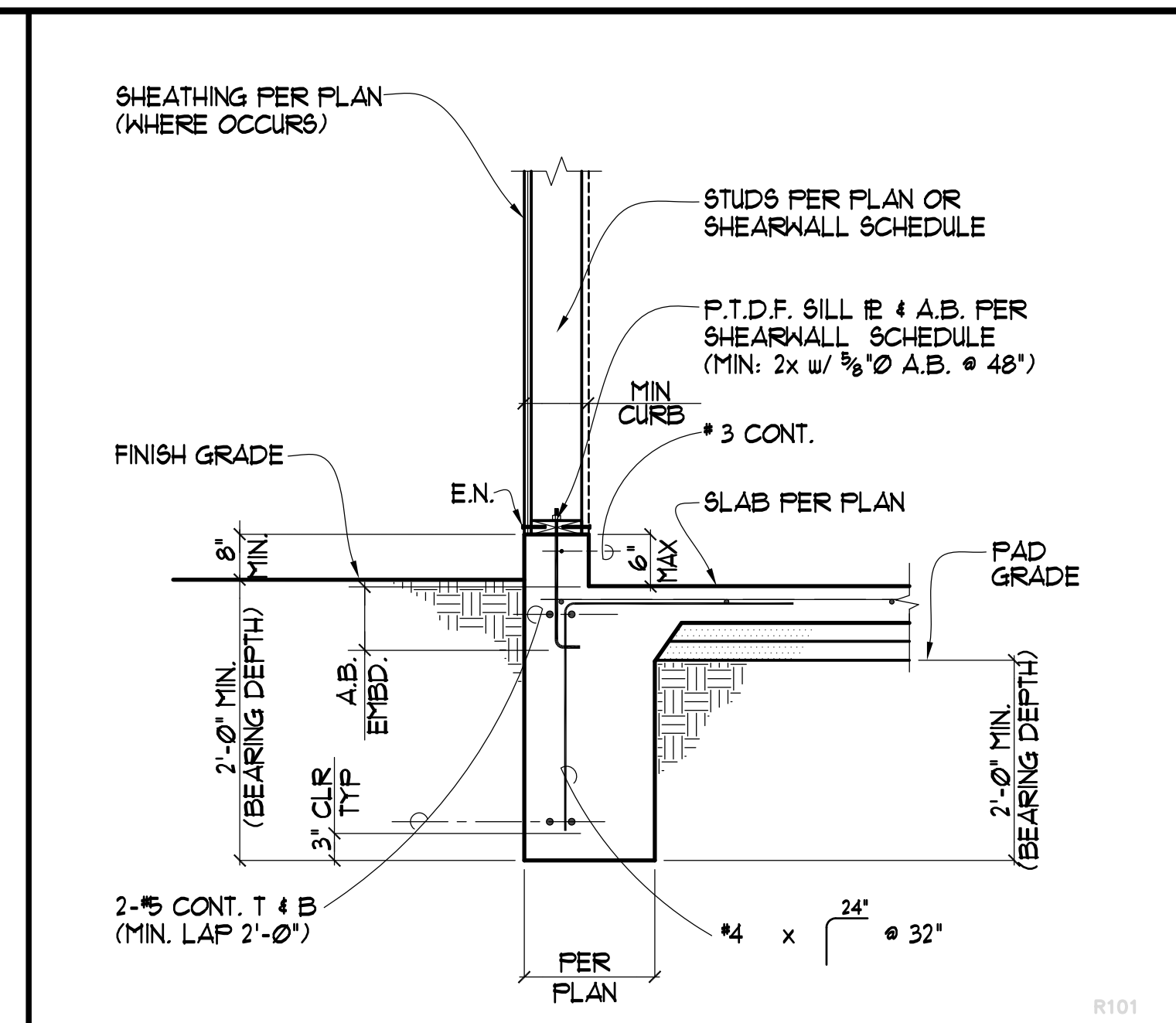

1 DETAIL

8 DETAIL

7 DETAIL

6 DETAIL

5 DETAIL

12 DETAIL

11 DETAIL

10 DETAIL

9 DETAIL

REVISION

| MARK | DATE | REVISIONS |
|------|------|-----------|
| 1 | | |
| 2 | | |
| 3 | | |

EC + Associates
engineering

8207 BROOKGREEN ROAD
DOWNEY, CA 90240
P: 562 708 3586

OWNER:
MR. EDUARDO J. CARRILLO

ADDRESS:
1248 CORONA DR.
GLENDALE, CA 91205

PROJECT ADDRESS:
1248 CORONA DR.
GLENDALE, CA 91205

CHECK AND VERIFY ALL DIMENSIONS BEFORE PROCEEDING WITH THE WORK. REPORT DISCREPANCIES TO THE ENGINEER. ALL CONSTRUCTION SHALL CONFORM TO THE C.B.C.

TITLE
FOUNDATION
DETAILS

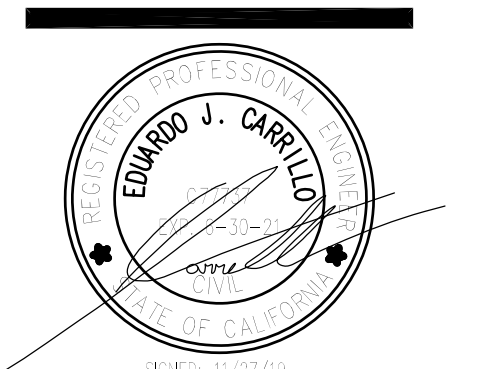

| | |
|----------------------|------------------|
| JOB #: 19-164 | DRAWN: U.P. |
| DATE: Nov. 27, 19 | CHECKED: E.C. |